

NEW MEXICO JUNIOR COLLEGE

BOARD MEETING
Thursday, March 21, 2002
Zia Room - Library
1:30 p.m.

AGENDA

- | | |
|-----------------------------------------------------------------------------------------------------------|--------------|
| A. Welcome | Mr. Newman |
| B. Adoption of Agenda | Mr. Newman |
| C. Approval of Minutes of February 28, 2002 | Mr. Newman |
| D. Correspondence | Mr. Schubert |
| E. President's Report | Dr. McCleery |
| F. Closure of Open Meeting | Mr. Newman |
| G. New Business | |
| 1. Monthly Expenditures Report | Dr. McCleery |
| 2. Monthly Revenue Report | Dr. McCleery |
| 3. Oil and Gas Revenue Report | Dr. McCleery |
| 4. Schedule of Investments | Dr. McCleery |
| 5. Consideration of RFP #63 - Provide Temporary Contract Labor | Dr. McCleery |
| 6. Consideration of RFP #66 - Professional Services for the Development of An Upward Bound Grant Proposal | Dr. McCleery |
| 7. Consideration of Bid #919 - Installation of Air Conditioning Units for NMJC Del Norte Center | Dr. McCleery |
| 8. Consideration of Bid #920 - Automotive Equipment & Supplies | Dr. McCleery |
| H. Public Comments | Mr. Newman |
| I. Announcement of Next Meeting | Mr. Newman |
| J. Adjournment | Mr. Newman |

NEW MEXICO JUNIOR COLLEGE

BOARD MEETING

FEBRUARY 28, 2002

MINUTES

The New Mexico Junior College Board met on Thursday, February 28, 2002, beginning at 1:30 p.m. in the Zia Room of Pannell Library. The following members were present: Mr. Monty Newman, Chairman; Mr. Gary Schubert, Secretary; Mr. Larry Hanna; Mrs. Yvonne Williams; Ms. Patricia Chappelle; Mr. Ferrel Caster; and Mr. John Hice, Jr.

Mr. Newman called the meeting to order and welcomed visitors and guests present: Starla Jones, Hobbs News Sun.

Upon a motion by Mr. Schubert, seconded by Mr. Caster, the agenda was unanimously adopted, as presented.

Upon a motion by Mr. Hice, seconded by Mr. Hanna, the board unanimously approved the minutes of January 31, 2002.

Under *President's Report*, Dr. McCleery expressed his appreciation to Mr. Hanna and Ms. Chappelle for their participation in the tuition credit round table discussion held on campus yesterday, as well as Ms. Chappelle serving on the Art In Public Places committee.

Under *New Business*, Mary Hinds with Johnson, Miller & Company presented the audit report for the fiscal year ending June 30, 2001. After some discussion and upon a motion by Mr. Schubert, seconded by Mr. Hanna, the board unanimously accepted the report.

Dan Hardin presented the January financial reports and with a motion by Mr. Hanna, seconded by Ms. Chappelle, the board unanimously approved the expenditures for January 2002.

Dr. McCleery presented a request to transfer \$16,000 from reserves to consulting and contract labor to be used for staff training on the administrative software. Upon a motion by Mrs. Williams, seconded by Ms. Chappelle, the board unanimously approved the request.

Mr. Collins presented Bid #914 - Janitorial Supplies. The administration recommended acceptance of the multiple awards bid totaling \$13,404.40. Upon a motion by Mr. Schubert, seconded by Mrs. Williams, the board unanimously accepted the recommendation.

Mr. Collins presented Bid #918 - Purchase of a Metallurgical Microscope. The administration recommended acceptance of the bid submitted by A.G. Heinze Precision MicroOptics, Shandler, AZ, for \$12,514.60. Upon a motion by Mr. Hanna, seconded by Ms. Chappelle, the board unanimously accepted the recommendation.

Steve Davis presented a request to approve new fees for nursing courses. The fees charged to the students will be put in a pass-through account for the customized assessment and review program. Upon a motion by Mr. Caster, seconded by Mr. Hice, the board unanimously approved the fees.

Mr. Newman called for comments from the community. There being none, the next board meeting was scheduled for March 21, 2002, beginning at 1:30 p.m. in the Zia Room of Pannell Library.

Upon a motion by Mr. Hanna, seconded by Mr. Schubert, the board meeting adjourned at 2:35 p.m.

CHAIRMAN

ATTEST: _____
SECRETARY

Others present:

Marilyn Jackson
Dan Hardin
Steve Davis
Richard Morris
Regina Organ

Bill Braun
Linda Neel
Renee Wharton
Bill Morrill

NEW MEXICO JUNIOR COLLEGE

Vice President for Finance

To: **New Mexico Junior College Board Members**
From: Dan Hardin
Date: March 15, 2002
RE: Expenditure and Revenue Reports for February

February represents month eight of the fiscal year or approximately 67% of the budget. The expenditure report represents expenditure totals that include funds expended and encumbered. At the end of February there was \$1,336,096.00 of the expenditures that were encumbered funds. The areas that are above the 67% of budget in Instruction and General are the Academic Support and Student Services. As we have stated in prior months, Academic Support has the Library purchases that were encumbered early in the year and Student Services has expended funds in areas such as student recruiting and Learning and Career Services that also had early seasonal expenditures.

The support departments that are over the normal percentage for February are the Internal Service Department, Student Aid, Auxiliary Enterprises, and Athletics. Internal Service Departments include Computer Services, Graphics and Motor Pool. The Computer Services Department and the Graphics Department have upfront funds expended for maintenance agreements and leases. The Computer Services Department is given a monthly credit from Instruction, Academic Support, Student Services and Institutional Support for their allocation for computer services. At this time, it appears that more funds have been expended than were budgeted. Each month \$55,147.00 will be credited to Computer Services. As the year progresses the amount included in the total year to date will decrease and should be within the projected budget at yearend. Student Aid has seasonal expenses for honors scholarships and tuition waivers. Student Aid will have some reimbursements that will cover the amount that is over budget. Auxiliary Enterprises include the Bookstore, Housing and Food Services. The Bookstore is above projected expenses, but they are also above their projected income.

Restricted student aid is above the projected budget. This area is the Pell Grants and Direct Loans that are draw down funds from the Federal Government.

In the Plant Funds the Purchase Order for the Caster Activity Center upgrade was encumbered, which is 1,047,734.01 of the amount in the Institutional Projects for the month of February.

The expense report for February reflects the payoff of the Dorm debt. The budget is less than the payoff, but the budget does not reflect any interest income from the funds set aside for debt service or beginning balances. The year to date total includes the payment in August and the payoff in February.

Most other areas in the expense report are in line for this time of year. The over all expenditures through the month of February are at 75% of the projected budget.

The revenue picture has some of the same features as the expenditure report. Tuition and Fees is a seasonal revenue stream. We have received almost all of the Tuition and Fees for the 2001/2002 fiscal year. State appropriations are consistent monthly revenue. Oil and Gas has two months of revenue \$239,201.48 for December and January has \$234,681.92 which is the actual income figures. We received \$329,082.77 in oil and gas equipment taxes, this makes oil and gas equipment taxes \$440,884.02 over projected budget. The total oil and gas for the month is \$802,966.17. We will start the modified accrual for oil and gas in March.

Under, Auxiliary Enterprises, the Bookstore revenue has been strong with year to date revenue of \$994,106.00.

Grant revenue starts at different times than the fiscal year. Grants normally begin in October and they are a draw down of funds after expenditures have been made. Grant expenditures are higher than the revenue side, but we should see the draw downs coming in over the next few months.

Student Aid consists of work study funds, Pell Grant Program and the Federal Direct Loan program. This is seasonal revenue funded at the start of each semester. Pell Grant program has brought in \$2,331,508.90 and the Direct Loan program is at \$886,049.00. At the start of each semester after tuition and fees are paid we hand out approximately \$800,000.00 to \$900,000.00 in pell and direct loans checks to our students. This is an economic boom for our area.

Total Revenue is ahead of projected budget revenue. In areas of revenue that is not seasonal the monthly income is tracking with or better than projections with the total revenue to budget percentage at 78%.

The month end investment total was \$9,325,000.00 in the Local Government Investment Pool. We have been very fortunate to have good cash flow, but we have a number of projects that will require draw downs from the LGIP fund.

This is the financial picture for February 2002.

NEW MEXICO JUNIOR COLLEGE
Expenditure Report
February 2002

67% of Year Completed

Fund	2000-01			2001-02			
	Final Budget	Year-to-Date Expended or Encumbered	Percentage of Budget Expended	Original Budget	Current Expended or Encumbered	Year-to-date Expended or Encumbered	Percentage of Budget Expended
CURRENT UNRESTRICTED FUND							
Instruction and General:							
Instruction	5,322,453	2,639,384	50%	5,980,600	480,709	3,334,384	56%
Academic Support	1,012,220	671,303	66%	1,021,222	109,961	869,132	85%
Student Services	1,020,190	687,682	67%	1,194,494	94,830	927,395	78%
Institutional Support	2,321,133	1,048,009	45%	2,461,574	171,683	1,521,038	62%
Operation & Maintenance of Plant	1,674,751	1,031,229	62%	1,943,012	314,855	1,216,407	63%
Subtotal - Instruction & General	11,350,747	6,077,607	54%	12,600,902	1,172,038	7,868,356	62%
Student Activities	118,724	72,167	61%	165,817	19,981	115,089	69%
Research	0	0	0%	0	0	0	0%
Public Service	24,968	329	1%	5,650	65	1,091	19%
Internal Service Departments	309,131	225,522	73%	300,815	42,156	372,511	124%
Student Aid	139,605	150,104	108%	148,092	1,616	156,639	106%
Auxiliary Enterprises	1,254,436	994,424	79%	1,266,820	190,106	1,476,203	117%
Athletics	558,129	387,218	69%	593,066	43,680	519,816	88%
Total Current Unrestricted Fund	13,755,740	7,907,371	57%	15,081,162	1,469,642	10,509,705	70%
CURRENT RESTRICTED FUND							
Grants	3,135,237	1,600,072	51%	2,236,954	233,374	1,532,858	69%
Student Aid	3,204,007	3,283,557	102%	3,300,000	74,647	3,656,458	111%
Total Current Restricted Fund	6,339,244	4,883,629	77%	5,536,954	308,021	5,189,316	94%
PLANT FUNDS							
Capital Outlay / Bldg. Renewal & Repl.				250,000		250,000	100%
Projects from Anonymous Grant				3,325,000	1,055,792	2,074,460	62%
Projects from Institutional Funds	2,126,546	764,148	36%	1,500,000	106,108	839,183	56%
Projects from State GOB Funds	0	0	0%	143,891		143,891	100%
Projects from State STB Funds	0	481,910	0%	6,163		6,163	100%
Projects from Other State Funds	116,172	110,009	95%	345,546	15,376	206,146	60%
Projects from State B R & R							
Subtotal - Capital and BR&R	2,242,718	1,356,067	60%	5,320,600	1,177,276	3,269,843	61%
Debt Service							
Revenue Bonds	264,845	133,541	50%	1,470,813	1,354,860	1,488,662	101%
Total Plant Funds	2,507,563	1,489,608	59%	6,791,413	2,532,136	4,758,505	70%
GRAND TOTAL EXPENDITURES	22,602,547	14,280,608	63%	27,409,529	4,309,799	20,457,526	75%

NEW MEXICO JUNIOR COLLEGE

Revenue Report

February 2002

67% of Year Completed

2000-01

2001-02

Fund	Final Budget	Year-to-date Revenue	Percentage of Budget Received	Original Budget	Current Month Revenue	Year-to-date Revenue	Percentage of Budget Received
CURRENT UNRESTRICTED FUND							
Instruction and General:							
Tuition and Fees	1,168,950	1,156,305	99%	1,244,954	12,198	1,218,631	98%
State Appropriations	6,566,300	3,815,800	58%	7,494,100	588,225	5,141,500	69%
Advalorem Taxes - Oil and Gas	2,500,000	2,826,353	113%	2,874,085	802,966	2,886,317	100%
Advalorem Taxes - Property	1,900,000	1,243,372	65%	1,900,000	26,627	1,350,005	71%
Interest Income	125,500	107,944	86%	75,000	18,571	91,217	122%
Other Revenues	384,886	132,193	34%	294,400	9,953	253,035	86%
Subtotal - Instruction & General	12,645,636	9,281,967	73%	13,882,539	1,458,540	10,940,705	79%
Student Activities	40,000	43,238	108%	43,400	76	42,717	98%
Public Service	0	37,100	0%	0	0	660	0%
Internal Service Departments	21,000	7,147	34%	14,000	1,680	12,506	89%
Auxiliary Enterprises	1,442,050	1,459,337	101%	1,528,300	19,812	1,610,585	105%
Athletics	33,600	19,970	59%	35,100	3,210	23,278	66%
Total Current Unrestricted	14,182,286	10,848,759	76%	15,503,339	1,483,318	12,630,451	81%
CURRENT RESTRICTED FUND							
Grants	3,135,237	820,751	26%	2,236,954	90,056	850,735	38%
Student Aid	3,204,007	2,627,421	82%	3,336,485	54,967	3,489,005	105%
Total Current Restricted	6,339,244	3,448,172	54%	5,573,439	145,023	4,339,740	78%
PLANT FUNDS							
Capital Outlay / Bldg. Renewal & Repl.							
Anonymous Grant				250,000		250,000	100%
Projects from State GOB Funds	0	0	0%	1,500,000	24,526	416,485	28%
Projects from State STB Funds	0	0	0%	143,891	0	143,891	100%
Projects from Other State Funds	116,172	0	0%	6,163	0	6,163	100%
Interest Income	0	67,155	0%	50,000	12,745	65,000	130%
Subtotal - Capital & BR&R	116,172	67,155	58%	1,700,054	37,271	881,539	52%
Debt Service							
Interest Income	55,000	48,287	88%	73,164	5,664	32,087	44%
Total Plant Funds	171,172	115,442	67%	1,773,218	42,935	913,626	52%
LOAN FUND							
Interest Income / Service Fees	0	0	0%	0	0	0	0%
Total Loan Fund	0	0	0%	0	0	0	0%
GRAND TOTAL REVENUES	20,692,702	14,412,373	70%	22,849,996	1,671,276	17,883,817	78%

NEW MEXICO JUNIOR COLLEGE

Oil and Gas Revenue Report

February 2002

59% of Year Completed

		OIL		GAS		COMBINED		
Sales	Month of Distribution	Price per BBL	Lea County BBLs sold	Price per MCF	Lea County MCF sold	Monthly Revenue	2000-01 Original Budget	Variance Over (Under) Budget
	May	\$24.78	5,412,518	\$5.47	18,046,880	360,106	208,250	151,856
	June	\$24.77	3,246,565	\$3.76	17,173,974	305,123	208,250	96,873
	July	\$25.78	3,258,367	\$2.55	17,191,397	330,045	208,250	121,795
	August	\$25.68	3,330,307	\$3.26	18,785,391	313,161	208,250	104,911
	September	\$25.05	3,279,532	\$2.65	18,519,464	288,115	208,250	79,865
	October	\$20.17	3,376,893	\$2.25	18,698,654	239,201	208,250	30,951
	November					234,682	208,250	26,432
	December						208,250	
	January						208,250	
	February						208,250	
	March						208,250	
Production Tax Revenue						2,070,433	2,499,000	612,683
Equipment Tax Revenue						815,884	375,000	440,884
Total Year-to-Date Oil and Gas Revenue						2,886,317	2,874,000	1,053,567

Source: New Mexico Taxation and Revenue Department

In order to stabilize the budgetary process for the 2001-02 fiscal year, oil and gas revenues were budgeted at a long-term historical average of \$16.00 per bbl for oil and \$2.50 per mcf for gas. It is recognized that actual collections will exceed this conservative historical average. Therefore, collections for the 2001-02 year that exceed this budgeted amount will be considered for transfer

NEW MEXICO JUNIOR COLLEGE
Schedule of Investments
February 2002

67% of Year Completed

Financial Institution	Amount Invested	Date Invested	Maturity Date	Period of Investment (Days)	Account Number	Interest Rate	Interest Earned
State of New Mexico Local Government Investment Pool	9,325,000	N/A	N/A	N/A	7102-1348	2.56%	18,716
Wells Fargo Bank of Hobbs	<u>0</u>	08/08/2001	02/08/2002	181	231611237	2.87%	<u>601</u>
Total investments	<u>9,325,000</u>						<u>19,317</u>

Summary of Current Month's Activity	
Beginning amount	8,075,000
Plus: deposits	1,250,000
Less: withdrawals	<u>0</u>
Ending amount	<u>9,325,000</u>

Capital Projects	2,822,869
Percentage of total investments	30%

NEW MEXICO JUNIOR COLLEGE

Request for Proposals #63

Provide Temporary Contract Labor

BOARD DOCUMENTS

Date:	March 14, 2002
Prepared by:	Frank Collins Coordinator of Purchasing

NEW MEXICO JUNIOR COLLEGE

BOARD DOCUMENTS

General Information

1. On February 11, 2002 a legal notice was posted on the NMJC Bulletin Board and sent to the following newspapers requesting sealed proposals to provide temporary contract labor for the college:
 - 1) The Hobbs Daily News Sun
 - 2) Albuquerque Journal
 - 3) Las Cruces Sun News
2. On February 11, 2002, proposal packets were delivered to four vendors.
3. One vendor submitted a proposal specified by the proposal package and in compliance with the opening date and time. One vendor submitted a proposal; however, it was not received by the Business Office until after the proposal opening time.
4. No bidders were present at the opening.
5. The Business Office has evaluated the proposal received and their recommendation is shown on Page 2.

NEW MEXICO JUNIOR COLLEGE

Evaluation and Recommendations

Board Documents

Two vendors responded to the Request for Proposals #63. Quest Personnel Inc., Hobbs NM and Spherion, Hobbs NM. Spherion's proposal was received after the proposal opening; therefore, it was considered non-responsive (delivered by U.S. Postal Service on February 28, 2002 between the hours of 12 Noon and 1:00 P.M.)

The scope of services, information on proven track record, list of references, and the fee structure were evaluated by the Evaluation Committee.

The Administration recommends acceptance of the services of Quest Personnel Inc., Hobbs NM. Please refer to Page 3 for the price structure and evaluation criteria.

Source of Funding: Consulting/Contract Labor

Account Number: 1-2231-13-332

Request for Proposal #63

Board Documents

Evaluation and Recommendation

Proposal Evaluation Criteria:

Section Number	Section Title	Percent	Total Points
I	Price	35%	350
II	Anticipated Availability	25%	250
III	Service	25%	250
IV	Years in Service	15%	150
		100%	1000

The Following Proposal was received:

Company Responding	Average Price	Points Section I	Points Section II	Points Section III	Points Section IV	Total Points Awarded
Quest Personnel Inc.	\$8.80	350	250	250	150	1000

Recommendation:

After a review of the submitted proposals the Business Office recommends accepting the proposal from Quest Personnel, Inc. for a contract to provide temporary contract labor for an initial period of one (1) year with an option for New Mexico Junior College to renew the contract each year for an additional one (1) year period, not to exceed three (3) renewals of the contract.

NEW MEXICO JUNIOR COLLEGE

BOARD DOCUMENTS

Specifications for Temporary Contract Labor

A. Scope

1. New Mexico Junior College anticipates the need for temporary contract labor at the main college campus and off-site campus locations in Lea County.
2. Possible places of service include, but are not limited to, Physical Plant, Custodial, Bookstore and various department offices.
3. The hours of work will vary with the individual assignment and scope of that assignment. Normal New Mexico Junior College office hours are 8:00 AM - 5:00 PM, Monday through Friday. Maintenance and Grounds is from 7:00 AM - 4:00 PM, Monday through Friday, Custodial hours are 11:00 PM - 7:00 AM, the Bookstore has normal operating hours from 8:00 AM - 6:00 PM Monday through Thursday and from 8:00 AM - 5:00 PM on Fridays. The Bookstore and some offices have extended hours during certain periods of the academic schedule. Some night and weekend work may be required. No overtime will be allowed.
4. The individual department will provide the contractor with the skills required of the temporary workers as per the assignment to which they are to be contracted at least a week prior to the beginning of an initial assignment. These skill requirements may be provided at the start of the contract period. Once New Mexico Junior College has provided the skill requirements to the contractor and the initial assignment has begun the contractor shall provide the labor on "as needed" basis with a minimum of one (1) working day notice.
5. The contractor will replace unsatisfactory workers within four (4) hours of being notified that the worker is unsatisfactory.
6. It is estimated that New Mexico Junior College will use between 2000 and 3000 hours of labor, however, it is understood that no guarantee or warranty is made or implied, by New

Mexico Junior College, or any other user, that an order for a definite quantity will be issued under this proposal.

B. Responsibilities of the Proposer

1. The successful contractor will provide for screening and determination of required assigning contract labor to New Mexico Junior College.
2. Any assignment of work will require the contractor to have in their possession a Purchase Order **(labor cost of \$1500.00 and greater)** from New Mexico Junior College or a Purchase Order Number as verified with the Purchasing Department of New Mexico Junior College, prior to the assigning of personnel to New Mexico Junior College.
3. The successful contractor will maintain all required insurances, business permits and surety bonds. The successful contractor will provide, upon request from New Mexico Junior College, background checks on any member of its work force that may be placed in a position that deal with money or potential control of New Mexico Junior College physical assets.
4. The successful contractor will bill each department separately, based upon the department's request for temporary laborers.
5. The successful contractor will make available a list of candidates that meets the skill requirements. New Mexico Junior College may elect to interview or to waive such interview and use the contract labor at the recommendation of the contractor. If the worker is for any reason unsatisfactory, New Mexico Junior College will notify the contractor who will replace said worker within four (4) hours. This four (4) hour requirement may be waived by requesting department and a different replacement time negotiated between the contractor and the department for that assignment.
6. The contractor will guarantee the worker. The contractor will not bill New Mexico Junior College for any worker, which has unsatisfactory performance, and is requested to be replaced by New Mexico Junior College to the contractor within the first four(4) hours of the assignment. Assignment is defined as a predetermined single continuous period of time for a department doing a specific type of job. Any change in job function in the same department, change of job to a different department or, not performing the designated function for a period of one (1) week shall be considered a new assignment.
7. The contractor will make restitution to New Mexico Junior College, after being presented with reasonable proof of a workers misconduct resulting in a loss of money or asset, within 30 days of the presentation of such reasonable proof.

C. General Categories of Worker (Skill requirements to be furnished by department after award)

General Maintenance Labor:

- A. Must be over 18 years of age
- B. Continuous stooping bending, lifting 50 pounds without assistance. Working off of a ladder.
- C. Must provide their own safety equipment. (Glasses, paper dust mask & back support belt)
- D. May require >75% of time out doors.

Custodial Labor:

- A. Must be over 18 years of age
- B. Continuous stooping bending, lifting 50 pounds without assistance. Working off of a ladder.
- C. Will include nights and weekend work.

Bookstore Clerk:

- A. Periodic stooping bending, lifting 50 pounds without assistance. Working off of a ladder.
- B. Standing or walking for >75% of the work day.
- C. Some overhead work required.
- D. May handle money and assets (background check required)

Office Personnel:

- A. May be sitting for >50% of work day.
- B. Some stooping bending, lifting 30 pounds without assistance.
- C. May require background check based on assignment.
- D. Requires typing, filing, telephone and general office skills

NEW MEXICO JUNIOR COLLEGE

Proposal Response Form

Temporary Contract Labor

The Following Evaluation Criteria will be used:

Price: 350 points (35%), Availability: 250 points (25%), Service: 250 points (25%) and Years in Service: 150 points (15%)

By the proposer's signature on page eight and at the bottom of this page, the proposer offers their services for the prices listed below in accordance with the terms and conditions of this proposal.

Price (Possible of 87.5 points each)

General Maintenance Labor \$ 9.38 / hour

Custodial Labor \$ 9.38 / hour

Bookstore Clerk \$ 8.21 / hour

Office Personnel \$ 8.21 / hour

**Anticipated Availability (Initial must be 1 week or less, replacement must be 4 hours or less)
(Possible 62.5 points each)**

General Maintenance Labor Initial 1 days Replacement 2 hours

Custodial Labor Initial 1 days Replacement 2 hours

Bookstore Clerk Initial 1 days Replacement 2 hours

Office Personnel Initial 1 days Replacement 2 hours

Service (50 points each)

1. Hours guaranteed under which unsatisfactory performance will not be billed? 4 (4 or more)

2. Can you be reached for replacement workers in the evening? yes

3. Can you be reached for replacement workers on weekends? yes

4. Do you provide detailed billing showing who worked and when? yes

5. Will you cover any loss from a theft by a contract employee within one (1) month of being presented with reasonable proof of the loss to New Mexico Junior College by your employee? yes

**NEW MEXICO JUNIOR COLLEGE
Proposal Response Form (continued)
Temporary Contract Labor**

Years in Service (must be in service two (2) years or more) Possible (150 points) Yes No

Copies of our Surety Bonds are attached? Yes No (circle one) If No please explain why not.

Signed by (Authorized Representative):

Carmie M. Ford

VERIFIED COPY OF POWER OF ATTORNEY
THE OHIO CASUALTY INSURANCE COMPANY
WEST AMERICAN INSURANCE COMPANY

No. 33-652

Know All Men by These Presents: That THE OHIO CASUALTY INSURANCE COMPANY, an Ohio Corporation, and WEST AMERICAN INSURANCE COMPANY, an Indiana Corporation, in pursuance of authority granted by Article VI, Section 7 of the By-Laws of The Ohio Casualty Insurance Company and Article VI, Section 1 of West American Insurance Company, do hereby nominate, constitute and appoint: **Carroll H. Leavell, Pam Driggers, Kim Fulfer, Kim McAdams, Beverly Bruner or Toni K. Dunn of Jal and/or Hobbs, New Mexico** its true and lawful agent (s) and attorney (s)-in-fact, to make, execute, seal and deliver for and on its behalf as surety, and as its set and deed any and all BONDS, UNDERTAKINGS, and RECOGNIZANCES, not exceeding in any single instance **ONE MILLION (\$1,000,000.00) DOLLARS**, including, however, any bond(s) or undertaking(s) guaranteeing the payment of notes and interest thereon

And the execution of such bonds or undertakings in pursuance of these presents, shall be as binding upon said Companies, as fully and amply, to all intents and purposes, as if they had been duly executed and acknowledged by the regularly elected officers of the Companies at their administrative offices in Hamilton, Ohio, in their own proper persons. The authority granted hereunder supersedes any previous authority heretofore granted the above named attorney(s)-in-fact.

In WITNESS WHEREOF, the undersigned officers of the said The Ohio Casualty Insurance Company and West American Insurance Company has hereto subscribed his name and affixed the Corporate Seal of each Company this 11th day of **JANUARY, 1999**.



Sam Lawrence

Sam Lawrence, Assistant Secretary

STATE OF OHIO,
COUNTY OF BUTLER.

On this 11th day of **Jan**,
Lawrence, Assistant Secretary
individual and officer described. **...**
that he is the officer of the Companies aforesaid, and that the seals affixed to the preceding instrument are the Corporate Seals of said Companies, and the said Corporate Seal and his signature as officer were duly affixed and subscribed to the said instrument by the authority and direction of the said Corporations.

...scribed, a Notary Public of the State of Ohio, in and for the County of Butler, duly commissioned and qualified, came **Sam Lawrence, Assistant Secretary** of **THE OHIO CASUALTY INSURANCE COMPANY and WEST AMERICAN INSURANCE COMPANY**, to me personally known to be the individual and officer described. I observed the preceding instrument, and he acknowledged the execution of the same, and being by me duly sworn deposed and said that he is the officer of the Companies aforesaid, and that the seals affixed to the preceding instrument are the Corporate Seals of said Companies, and the said Corporate Seal and his signature as officer were duly affixed and subscribed to the said instrument by the authority and direction of the said Corporations.

IN TESTIMONY WHEREOF, I have hereto set my hand and affixed my Official Seal at the City of Hamilton, State of Ohio, this day and year first above written.



Barbara Hoffman

Notary Public in and for County of Butler, State of Ohio
My Commission expires **September 25, 2002**.

This power of attorney is granted under and by authority of Article VI, Section 7 of the By-Laws of The Ohio Casualty Insurance Company and Article VI, Section 1 of West American Insurance Company, extracts from which read:

Article VI, Section 7. APPOINTMENT OF ATTORNEYS-IN-FACT, ETC. "The chairman of the board, the president, any vice-president, the secretary or any assistant secretary of each of these Companies shall be and is hereby vested with full power and authority to appoint attorneys-in-fact for the purpose of signing the name of the Companies as surety to, and to execute, attach the corporate seal, acknowledge and deliver any and all bonds, recognizances, stipulations, undertakings or other instruments of suretyship and policies of insurance to be given in favor of any individual, firm, corporation, or the official representative thereof, or to any county or state, or any official board or boards of county or state, or the United States of America, or to any other political subdivision."

Article VI, Section 1. APPOINTMENT OF RESIDENT OFFICERS. "The Chairman of the Board, the President, any Vice President, a Secretary or any Assistant Secretary shall be and is hereby vested with full power and authority to appoint attorneys in fact for the purpose of signing the name of the corporation as surety or guarantor, and to execute, attach the corporate seal, acknowledge and deliver any and all bonds, recognizances, stipulations, undertakings or other instruments of surety-ship or guarantee, and policies of insurance to be given in favor of an individual, firm, corporation, or the official representative thereof, or to any county or state, or any official board or boards of any county or state, or the United States of America, or to any other political subdivision."

This instrument is signed and sealed by facsimile as authorized by the following Resolution adopted by the respective directors of the Companies (adopted May 27, 1970-The Ohio Casualty Insurance Company; adopted April 24, 1980-West American Insurance Company):

"RESOLVED that the signature of any officer of the Company authorized by the By-Laws to appoint attorneys in fact, the signature of the Secretary or any Assistant Secretary certifying to the correctness of any copy of a power of attorney and the seal of the Company may be affixed by facsimile to any power of attorney or copy thereof issued on behalf of the Company. Such signatures and seal are hereby adopted by the Company as original signatures and seal, to be valid and binding upon the Company with the same force and effect as though manually affixed."

CERTIFICATE

I, the undersigned Assistant Secretary of The Ohio Casualty Insurance Company and West American Insurance Company, do hereby certify that the foregoing power of attorney, the referenced By-Laws of the Companies and the above Resolution of their Boards of Directors are true and correct copies and are in full force and effect on this date. IN WITNESS WHEREOF, I have hereto set my hand and the seals of the Companies this _____ day of _____



Mark L. Schmidt
Assistant Secretary

OVERVIEW OF QUEST PERSONNEL, INC.

EQUAL OPPORTUNITY EMPLOYER

Quest Personnel, Inc. is an equal opportunity employer. All qualified applicants will receive consideration for employment without regard to race, color, religion, sex, age, national origin, national ancestry, physical handicap or marital status. Quest Personnel, conforms to all applicable federal regulations and guidelines guaranteeing equal employment opportunity for qualified handicapped individuals, and disabled veterans. Decisions on employment will be based solely on the qualifications to further the principle of equal employment opportunity. Our policy is to be fair and impartial in all of our relationships with our employees and applicants.

EMPLOYMENT ELIGIBILITY VERIFICATION

Quest Personnel complies with applicable regulations with regard to the U.S. Immigration Reform Control Act of 1986.

AMERICANS WITH DISABILITIES ACT

Quest Personnel has knowledge of the American's with Disabilities Act of 1991 and is compliance with all applicable regulations.

APPLICANT EVALUATION

The key to providing our customers with effective, productive temporaries is our evaluation process.

Applicant Selection

All temporaries furnished by Quest are evaluated, reference checked, interviewed and tested by experienced staff. Quest certifies by means of personal interviews, work reference checks, and skill tests. The temporary provided will have the learning ability, the necessary work aptitude, the skills, and work record to perform the assignment for which they are assigned.

Applicant Testing

Quest Personnel administers a variety of tests that allows us to analyze the range and depth of an applicants' skills. All applicants are given a basic skills test which evaluates them on spelling, math, filing, and proofreading skills. Another program Quest utilizes is the Prove It! Skills Evaluation System. This program can be used to test the applicant's proficiency in the following:

Secretarial

Speed typing	Letter Typing
Ten Key	Shorthand
Data Entry/Alpha	Data Entry/Numeric
Statistical Typing	

Word Processing

WordPerfect 5.1/6.0	Word for Windows 2.0/6.0/7.0
MS Word 5.5/6.0	Word Pro 96

Ami Pro

These are just a few of the tests in word processing; we have others in addition to the above, as well as "advanced testing" in various word processing software.

Spreadsheet Tests

Excel	Quatro Pro (DOS and Windows)
Lotus 1-2-3 (DOS and Windows)	

Advanced Legal/Medical Tests

Customized Testing

This feature of **Prove It!** allows either Quest Personnel or our clients to design and implement both industry and position specific testing.

Assignment Process

Before assigning a temporary employee, Quest Personnel will visit the customer site to learn details about the company, equipment to be used and any other information needed for pre-assignment orientation. The result is the best match of a Quest Temporary to your company's specific needs.

EMPLOYEE/CUSTOMER INTERVIEW

Quest Personnel will provide resumes and will schedule interviews necessary to accommodate client companies in choosing the best qualified candidate for the temporary assignment. The service is provided without additional cost.

SECURITY & CONFIDENTIALITY

Our employees maintain high ethical standards in handling correspondence, invoices, proprietary information, currency, and trade secrets. It is agreed that all phases of the job are to be considered confidential and the sole property of the client company. Upon request, each temporary will sign a **NON DISCLOSURE OF INFORMATION** statement.

TEMP TO HIRE POLICY

Quest Personnel will allow a client to hire any temporary onto their payroll without a fee after the temporary has completed a specified number of hours.

RECRUITING

Quest Personnel has the ability to recruit personnel with a proven track record should a special skill be required.

Quest Personnel utilizes the following areas to attract and recruit applicants:

1. **Newspaper and Direct Mail:** Quest Personnel uses newspaper and direct advertising activities to attract interested applicants.
2. **Referral:** We find that our best recruiting is accomplished through referrals, from clients, temporaries, or individuals in the business community who are aware of Quest Personnel's staffing reputation.

ONE HOUR CALL-BACK GUARANTEE

Quest Personnel will respond to all temporary requests within one hour after receiving the request to confirm employee(s) assigned. We have the capability of supplying personnel within one hour, however 24 hours would provide optimum lead time.

Minimum time for which clients can request and be billed for a short term temporary assignment is four (4) hours.

GUARANTEE

Quest Personnel is committed to excellence and stands behind its quality customer service with a four (4) hour guarantee. Should a temporary employee prove unsatisfactory, (for any reason) your company should notify Quest Personnel within the first four (4) working hours and the client will not be billed for this time. A replacement will be provided if so requested.

QUALITY CONTROL CHECKS

A call is made to the client mid-day on the first day of the assignment to be sure the temporary's performance is meeting their expectations. Also, the account representative will stop by in person by the end of the day.

TROUBLE FREE PAYROLL ORIENTATION

Trouble Free Payroll policy allows you to exercise all the control that you normally use when hiring a permanent employee, but none of the paperwork or risk. You screen to your specifications and decide who you want to work for you. You decide the start date and the pay scale. Quest Personnel does the rest. Not only do we pay the temporary employee's salary, but also all taxes, worker's compensation, etc. This works especially well for summer employees and college students your firm wants to employ, as well as previous employees called back for special assignments. Some clients use Trouble Free Payroll during a probationary period, or while awaiting results of pre-employment tests.

Trouble Free Payroll applies to all positions within your firm from executive, to accountants, to secretaries, to mail room clerks. We also possess unlimited payroll capabilities.

TEMPORARY ORIENTATION

Prior to being sent on an assignment, Quest temporaries are oriented in the areas of office protocol, business wardrobe, confidentiality of information, reliability, and quality of performance. They are also aware of each particular company's corporate culture which would include an overview of their business, work hours, dress code, and telephone procedures.

TEMPORARY BENEFITS

Quest Personnel offers a variety of benefits to our temporaries including:

- Good jobs in a supportive environment
- Equitable pay rates
- Holiday pay after a designated number of hours are worked
- Opportunity to enroll in a health insurance program
- Cash bonuses for candidates referred to Quest Personnel who work a minimum of 40 hours
- Vacation pay after a designated number of hours are worked
- Opportunity for full time employment



Temporary and Permanent Staffing

1601 N. TURNER
SUITE 510
BROADMOOR TOWER
HOBBS, NEW MEXICO 88240
OFFICE (505) 393-1585
FAX (505) 393-7762

From: Jeff Reagan, President of Quest Personnel
Subject: COMPANY SAFETY AND HEALTH POLICY

The personal safety and health of each employee of this company is of primary importance. The prevention of occupationally induced injuries and illnesses is of such consequence that it will be given precedence over operating productivity whenever necessary.

Our goal is to offer our clients the best total solution to their staffing problems. To do that we must provide the highest levels of Safety, Quality and Service.

We believe that accidents and injuries can be prevented. We believe that safety is not separate from the job, it is how we do our jobs.

Accidents are a waste of human potential and a source of economic hardship for the injured worker and his/her family. Accidents lower the quality of the service we provide our clients. Accidents are disruptive to our clients' business and raise costs.

Our objective is a safety and health program that will reduce the number of injuries to a minimum, not merely in keeping with, but surpassing, the best experience in the staffing industry. Our Safety and Health Program will include:

1. Conducting a program of safety and health inspections to find and get rid of unsafe working conditions or practices; to control health hazards; and to comply fully with the safety and health standards for every job.
2. Training of all employees in good safety and health practices.
3. Developing and enforcing safety and health rules; requiring that employees cooperate with these rules as a condition of employment.
4. Investigating, promptly and thoroughly, every accident to determine its cause and correct the problem so that it will not be repeated.

In the supplemental staffing industry, it is absolutely essential that we work together with our clients to build and maintain safe and healthy work environments. Because we do not have economic control of our clients' facilities, it is doubly important that we be involved in constructive, consultative ways to assist the client in maintaining an active and effective accident and loss control program.

It is our philosophy to only work with those clients who express willingness to provide safe working environment for our employees. We will not do business with those prospective clients who work in particularly dangerous industries or who show a disregard for the safety and well being of their own or our employees. We will never knowingly put our employees at risk.

NEW MEXICO JUNIOR COLLEGE

Request for Proposals #66

**Professional Services for the Development of An
Upward Bound Grant Proposal**

BOARD DOCUMENTS

Date:	March 11, 2002
Prepared by:	Frank Collins Coordinator of Purchasing

NEW MEXICO JUNIOR COLLEGE

BOARD DOCUMENTS

General Information

1. On February 12, 2002 a legal notice was posted on the NMJC Bulletin Board and sent to the following newspapers requesting sealed proposals for professional services for the development of an Upward Bound Grant Proposal:
 - 1) The Hobbs Daily News Sun
 - 2) Albuquerque Journal
 - 3) Las Cruces Sun News
2. On February 12, 2002, proposal packets were delivered to six (6) potential bidders.
3. Only one vendor submitted a proposal specified by the proposal package.
4. No bidders were present at the opening.
5. The Business Office has evaluated the proposal received and their recommendation is shown on Page 2.

NEW MEXICO JUNIOR COLLEGE

Evaluation and Recommendations

Board Documents

Only one vendor responded to the Request for Proposal #66. Ramona Munsell & Associates ("RMA"), Bella Vista, AR was the sole offeror for this Request.

The scope of services, information on proven track record, list of references, and the fee structure were evaluated by the Business Office.

The Administration recommends acceptance of the professional services of Ramona Munsell & Associates for an award amount equal to 3.5% of the annual grant award during the term of the grant. (Estimated grant award is \$309,730) to be paid in equal quarterly installments commencing with the date the grant begins. Estimated annual fee would be \$10,840.55.

Source of Funding: Consulting/Contract Labor (NMJC Share)

Account Number: 1-2231-13-332

The contingency fee would commence in the 2002/2003 budget year and would be an annual budgeted expenditure in a consulting services account 1-2231-13-332 each year throughout the grant's funding cycle.

NEW MEXICO JUNIOR COLLEGE

BOARD DOCUMENTS

Specifications for:

Professional Services for the Development of a Upward Bound Grant Proposal

1. New Mexico Junior College is requesting proposals for professional services to develop a full and comprehensive **Upward Bound** ("UB") grant proposal for submission to the United States Department of Education as authorized under Title IV of the Higher Education Act of 1965, as amended. Services provided by Offerors must include all necessary assistance in developing a successful proposal under Title IV. The successful Offerors will assist the College's staff in all stages of the full development and guaranteed submission of a Title IV SSS proposal by the 2002 deadline date as established by the Secretary of the U.S. Department of Education. The anticipated deadline for the grant proposal is October 31, 2002.
2. Prospective Offerors must submit a documented, proven track record of major success in obtaining new or renewal grants for other institutions under title IV of the Higher Education Act of 1965, as amended. Offerors must submit a minimum of five (5) client references, with names and telephone numbers of institutional representatives involved in program administration.
3. The successful offeror must provide all grant management assistance in establishing appropriate program and fiscal controls, internal monitoring and evaluation systems during the term of the successfully approved grant.
4. The successful offeror must provide assistance in all performance reporting requirements during and after the term of the grant, any audits following the conclusion of a grant and/or continuation grants (s) under Title IV during the term of any agreement with New Mexico Junior College.
5. Offerors who agree to perform services on a contingency basis will be given preference. Upon receipt of official notice of a grant award, the fee will be payable on a quarterly basis over the Trio fiscal year term (September 1, 2003 – August 31, 2004) for all professional services and consultations to be rendered.
6. Due to the significant amount of time needed to ensure a successful application process and thorough implementation of the Upward Bound Program, preference will be given to offerors who are full-time independent consultants, specializing in Federal grants, who are not regular employees of other colleges or universities.

7. Offerors must submit a complete firm profile, including resumes of key personnel, with their proposals. Offerors must include a time line and plan of approach with their proposals and any other relevant information for NMJC to properly evaluate the services specified in this RFP.

**NEW MEXICO JUNIOR COLLEGE
Request for Proposals #66**

Proposal Response Form

Professional Services for the Development of a Upward Bound Grant Proposal

The following Evaluation Criteria will be used:

Section 1	Price	300 points	(30%)
Section 2	Full-time consultant	250 points	(25%)
Section 3	Success rate track record@@	250 points	(25%)
Section 4	Ability to provide excellent service	200 points	(20%)

@@Please provide a list of successful federally funded projects relating to TRIO programs in the past two TRIO cycles (SSS, Upward Bound, Talent Search).

Section 1: Price (Potential = 300 points)

Initial Administrative Fee for Proposal Completion and Submission \$ _____

Percentage of Annual Grant Award Contingency Fee _____%

Section 2: Full time consultant (Potential = 250 points) Yes / No

Section 3: Success Rate Track Record (Potential = 250 points)

A. Successful federally funded projects relating to TRIO programs in past two TRIO cycles Yes / No

Section 4: Ability of consultant to provide excellent professional services to New Mexico Junior College (Potential = 200 points)

Submit information and client references as specified.

TOTAL POINTS - (MAXIMUM OF 1,000 POINTS)

RAMONA MUNSELL & ASSOCIATES

**RESPONSE TO NEW MEXICO JUNIOR
COLLEGE RFP #66**

**Professional Services
for the
Development of an
Upward Bound Grant
Proposal**

March 8, 2002

TO: New Mexico Junior College
Administration Building - Business Office
Frank Collins, Coordinator of Purchasing
5317 Lovington Highway
Hobbs, New Mexico 88240

FROM: Ramona Munsell, President
Ramona Munsell & Associates
26 Musselburgh Lane
Bella Vista, Arkansas 72715
(501) 855-7717 Voice Transmission
(501) 855-7727 Fax Transmission
rjmunsell@aol.com Electronic Mail
71-0717144 Federal I.D. No.

SUBJECT: Request for Proposals #66: Professional Services for the Development of an Upward Bound Grant Proposal

DATE: March 8, 2002

DOCUMENTATION

Accompanying this cover memo, please find the following material submitted in support of this response to the specifications of the New Mexico Junior College Request for Proposals #66 for grantwriting / management consulting services.

- (1) Vendor Data Form
- (2) RFP #66 Proposal Response Form
- (3) General information about Ramona Munsell & Associates.
- (4) Scope of services offered by Ramona Munsell & Associates.
- (5) Information on proven track record and list of references.
- (6) Timeline and Plan of Approach
- (7) Fee structure and a copy of Ramona Munsell & Associates' standard Memorandum of Understanding.

If additional information is required, please do not hesitate to call.

NEW MEXICO JUNIOR COLLEGE

VENDOR DATA FORM

Title: RFP #66 - Professional Services for the Development of an Upward Bound Grant Proposal

The following information must be completed and returned with your proposal:

NEW MEXICO RESIDENTIAL PREFERENCE (if applicable)

Residential Preference Number N/A

Is material grown, produced or wholly manufactured in New Mexico? Yes or No

BUSINESS SIZE / CLASSIFICATION

Small Business Concern

Disadvantaged Business Concern

Large Business Concern

Women Owned

Please note that the above information is for reporting purposes only and will not be used in evaluating or awarding the contract.

ACKNOWLEDGMENT OF ADDENDA (if applicable):

The undersigned acknowledges receipt of the following addendum

Addendum No. N/A Dated

Addendum No. N/A Dated

The undersigned, as an authorized representative for the company named below, acknowledges that he / she has examined this Request for Proposals with its related documents, and, being familiar with all the conditions surrounding the described materials and / or services, including the availability of materials and labor, hereby offers to furnish all labor, materials and supplies necessary to comply with the specifications in accordance with the General Terms and Conditions set forth herein and at the prices stated on the Proposal Response Form.

Company Name: Ramona Munsell & Associates Address: 26 Musselburgh Lane

City, State, Zip Code: Bella Vista, AR 72715 Federal ID# or SSN: 71-0717144

Signature of Authorized Representative: *Ramona Munsell*

PRINTED OR TYPED:

Name: Ramona Munsell

Title: President

Date: March 8, 2002

Phone # 479-855-7717

FAX # 479-855-7727

**NEW MEXICO JUNIOR COLLEGE
Request for Proposals #66
Proposal Response Form**

Professional Services for the Development of an Upward Bound Grant Proposal

The following Evaluation Criteria will be used:

Section 1	Price	300 Points	(30%)
Section 2	Full-time Consultant	250 Points	(25%)
Section 3	Success rate track record@@	250 Points	(25%)
Section 4	Ability to provide excellent service	200 points	(20%)

@@Please provide a list of successful federally funded projects relating to TRIO programs in the past two TRIO cycles (SSS, Upward Bound, Talent Search).

Section 1: Price (Potential = 300 points)

Initial Administrative Fee for Proposal Completion and Submission \$0

Percentage of Annual Grant Award Contingency Fee 3.5%

Section 2: Full time consultant (Potential = 250 points) Yes No

Section 3: Success Rate Track Record (Potential - 250 points)

A. Successful federally funded projects relating to TRIO programs in past two TRIO cycles Yes No

Section 4: Ability of consultant to provide excellent professional services to New Mexico Junior College (Potential = 200 Points)
Submit information and client references as specified.

Total Points - (MAXIMUM OF 1,000 POINTS)

By offeror's signature on page five and at the bottom of this page, the offeror proposes to provide services in accordance with the terms and conditions of this proposal.

Signature of Authorized Representative: _____

Ramona Russell

Title: President

Date: March 8, 2002

GENERAL INFORMATION ABOUT RAMONA MUNSELL & ASSOCIATES

A PROVEN RESOURCE FOR INSTITUTIONAL IMPROVEMENT

Ramona Munsell & Associates (RMA) is a private educational consulting agency which specializes in providing Title III / V and Title IV (TRIO) Program-related services to higher education institutions throughout the country. Although Ramona Munsell & Associates is a small agency with a narrow focus, it has a well-established reputation both for helping colleges succeed in obtaining large federal grants and for helping colleges implement successful projects with these grants. The agency has worked with over 200 colleges and universities with enrollments ranging in size from less than 500 to over 20,000 students.

The agency was established in 1984 by Ramona Munsell. Although the founder had substantial expertise in several areas of grantwriting and broad educational experience, she decided to focus the new consulting business on helping institutions obtain Title III and Title IV funds and use these funds to maximum institutional advantage. The main reason was the extent of her knowledge about these programs and their potential to support significant institutional improvement. Ramona Munsell has been involved with the Title III program for over eighteen years and Title IV for eleven years. She is recognized as an authority on all aspects of the Title III / V programs. In 1991, husband Don Munsell, who also has extensive experience in grantwriting, joined the consulting agency full-time.

In addition, the staff of Ramona Munsell & Associates now includes a few carefully selected associates who serve as consultants with client institutions representing RMA. Associates of RMA have extensive Title III / V and Title IV-related experience and / or proven grantwriting ability, and each associate brings a unique perspective to his / her work with RMA as a consultant. These associates greatly expand the capability of the agency to serve client institutions. Adding associates has enhanced the capability of RMA to help client institutions succeed in winning federal grants as the competition for these grants has increased. The selection process of grants is highly subjective. Nevertheless, the chance of success is greater if the effort is guided by the type information RMA can provide colleges as a result of the diverse backgrounds of the agency's directors and associates and their collective experiences.

All members of the Ramona Munsell & Associates staff have extensive higher education experience and are committed educators. Before becoming a full-time consultant, Ramona Munsell spent eight years as a faculty member and administrator at a college in the midwest. She and most associates who work with her initially became involved in grantwriting in order to help their own institutions obtain federal funding. The staff of Ramona Munsell & Associates understand the funding "game" but they also understand that federal grants are only valuable if they are a means to achieve significant institutional goals.

Type of Title IV (TRIO)-related services offered by Ramona Munsell & Associates include:

- 1) **Assistance in preparing a proposal.** Services available range from technical assistance in planning the project and the proposal to the writing of the entire proposal. We believe that homegrown proposal guided and informed by our savvy have the greatest chance of success and impact.
- 2) **Grant management assistance.** Services available focus on helping the institution manage the TRIO projects after funding is awarded in such a way that the funding itself is never jeopardized, the projects operate in full accordance with federal rules and regulations, and the projects are as beneficial as possible to the institution. We want to enable the project manager and all participants to focus on the projects not the federal red tape.
- 3) **Consulting services.** All members of the staff are qualified to serve as expert consultants in a wide range of institutional development areas. RMA provides at least two onsite visits each year and unlimited telephone consulting for technical assistance.
- 4) **Supplemental Funding.** TRIO and Title V often offer opportunities to grantees for supplemental funding. RMA provides assistance to clients in writing requests for supplemental funding.

***Types of Title IV (TRIO) funded projects assisted by
Ramona Munsell & Associates in the last three years:***

UPWARD BOUND	STUDENT SUPPORT SERVICES	EDUCATIONAL TALENT SEARCH
<ul style="list-style-type: none"> • Summer programs of instruction to assist students in college prep courses • Academic, financial, and personal counseling • Exposure to academic programs and cultural events • Information on postsecondary opportunities and assistance in completing college entrance and financial aid applications • Instruction in reading, writing, study skills, and other subjects necessary for success in education beyond high school 	<ul style="list-style-type: none"> • Instruction in basic skills • Tutorial services • Academic, financial, or personal counseling • Assistance in securing admission and financial aid for enrollment in four-year institution • Information about career options • Mentoring • Special services for students with limited English proficiency 	<ul style="list-style-type: none"> • Academic, financial, career, or personal counseling • Advice on entry or re-entry to secondary or postsecondary programs • Career exploration • Tutorial services • Exposure to college campuses • Information on postsecondary education • Assistance in completing college admissions and financial aid applications • Mentoring programs • Special activities for 6th, 7th, and 8th graders • Workshops for parents of participants

SPECIFICS ABOUT RMA'S SERVICES

A breakdown of services to be provided client institutions upon request after funding:

Services Relevant to Project Management - TRIO

1. Technical assistance in establishing a time-accounting system which complies with federal regulations and also meets institutional needs.
2. Technical assistance in internal administration of the project including establishing an accounting system which complies with Federal and State regulations.
3. Technical assistance in budget management, revisions and documentation for purchases, and assistance in resolving budget problems on request.
4. Consultation regarding procedures to be followed to establish and maintain control and accountability in program and budget matters.
5. Response to all questions regarding policy, practice and regulations as they affect internal operations of the project and any other related areas of the institution.
6. Telephone/fax and on-site consultation, as needed, concerning grant personnel, budget and equipment issues.
7. Assistance to the college in responding to all federal requests for information/reports, including preparation of any reports required for continued funding.
8. Consultation concerning external review and analysis of the status of the college project - - including fiscal management and progress toward objectives.
9. Review and editing of all materials related to the project provided by the Project Coordinator/Director.
10. Consultation concerning monitoring and documenting project achievements as required by federal regulations.
11. Consultation on-site with college and grant personnel concerning grant management and project administration.
12. Monitor changes within TRIO legislation which might be reflected in the institution grant awards, budgets, etc.
13. Prompt, continuous information about changes in federal regulations and operations which affect the project.
14. Information about official TRIO technical workshops.
15. Notification of opportunities for supplemental Upward Bound funding and assistance with applications for supplemental funds.

EXPERIENCE AND KNOWLEDGE REQUIREMENTS

Ramona Munsell & Associates maintains comprehensive current information about all aspects of the TRIO, Title III and Title V. With over eighteen years of consulting experience, RMA staff are familiar with every type of grant management issue. All associates are well informed and knowledgeable about the current regulations, including HSI regulations. Ramona Munsell has served as Project Manager for seven Title III / TRIO projects in three states. Presently, Ramona Munsell & Associates works with numerous institutions with large Hispanic enrollment. All associates are knowledgeable about the special needs of underserved and underrepresented students and how colleges can address these needs with TRIO and Title III/V funding.

- Ramona Munsell & Associates has monitored and maintains comprehensive information about the development and implementation of TRIO and Title III/V projects.
- Ramona Munsell & Associates personnel regularly attend TRIO and Title III technical workshops designed for potential applicants and for continuing grantees. The agency monitors and maintains a constantly updated set of files which include the following:
 - All Federal Register references to TRIO and Title III/V;
 - Education Department General Administrative Regulations (EDGAR);
 - Program-specific TRIO and Title III/V Regulations including all Hispanic-Serving Institutions (HSI) Grant Regulations;
 - Grant Terms and Conditions - Institutional award documents;
 - Guidelines for application for new and continuation grants;
 - Guidelines for establishing and maintaining Title III/V and HSI eligibility;
 - OMB circular A-133, Audits of Institutions of Higher Learning and other Non-Profit Institutions;
 - All related Program Management and Monitoring materials distributed by the Department of Education in Washington, D.C. at technical workshops; and
 - Sample Performance Reports for TRIO and Title III/V projects.

Ramona Munsell & Associates is well informed about federal monitoring and audit rules, policies and procedures so that we can help our client colleges prepare for and handle federal visits or inquiries. We provide immediate assistance to our clients when they have questions about or problems with the funding agency.

RMA regularly provides its clients with professional quality, current grant management materials including sample record keeping and documentation forms, suggested fiscal procedures, etc. and guidelines for all areas of grant management. RMA client colleges can focus on the project's purpose with the comfort of knowing that the project is in compliance with federal regulations. This is very difficult to achieve with dependence on federal officials. Materials are updated promptly when there are changes in federal law or policy relevant to TRIO and Title III/V.

RAMONA MUNSELL

**PRESIDENT, RMA
SENIOR ASSOCIATE, WRD
VITA – (ABRIDGED FORM)**

Ramona Munsell has worked with federal grant programs for the past eighteen years, has served as a consultant for numerous colleges and universities since 1984, and has served as the project manager of seven different grants. Ms. Munsell has an outstanding TRIO and Title III / V track record and a well-established reputation in grantwriting, a field in which she has worked as a full-time consultant since 1989. She is a Senior Associate of Western Resource Development (WRD), a highly successful consulting firm on the west coast that specializes in Title III / V. Ramona secured funding for the only colleges in the states of Arizona, Iowa, Illinois, Massachusetts and Missouri to receive a Title III grant in 1998, the only colleges in the states of Iowa, Kentucky, and New Mexico to receive a Title III grant in 1999, the only colleges in the states of Kansas and Alaska to receive a Title III grant in 2000, the only colleges in the states of Alaska, Arkansas, Kansas, and Texas to receive a Title III grant in 2001, and was responsible for the first Title III grants ever awarded in the states of Nevada and Alaska. She also had Title III applications which scored three perfect 100's in the last four cycles. Although Ramona has more Title III experience, she has an equally impressive track record in TRIO. She is President of Ramona Munsell & Associates, a consulting agency specializing in federal TRIO, Title III and Title V programs. Working primarily with new rather than existing projects in the past four years, Ramona has nearly 50 colleges secure new TRIO grants. Ramona Munsell & Associates is presently working with over 100 colleges and universities in 20 states.

RELATED PROFESSIONAL EDUCATION EXPERIENCE

Ramona Munsell has had extensive experience in higher education. She combines three years of college English instruction with eight years of administrative experience at Fort Scott Community College – a small rural public community college in Kansas. As Dean of Development at Fort Scott, Ramona established and directed a highly successful comprehensive resource development program that was recognized as a state-wide model. At the time of her departure, FSCC had the largest community college endowment fund in the state and was ranked twelfth in the nation in alumni giving. While at Fort Scott, Ramona was successful in obtaining several millions of dollars in grants including one of the first National Science Foundation grants awarded to two-year colleges, two consecutive Title III Strengthening grants and two consecutive Title III Endowment Challenge grants. As Dean of Development, Ms. Munsell was responsible for all resource development functions (grantwriting and grant management, foundation, alumni programs, friend- and fund-raising programs); established and directed the institutional strategic planning process; chaired the North Central self-study process; administered and funded the college's basic skills learning center. The comprehensive, multi-purpose learning center, which was funded by eight different grants, also served as a state-wide model and was selected as one of ten programs nationwide to receive the National Showcase of Excellence Award in 1988.

Ramona left the College in October of 1989 to focus on full-time consulting and pursue a doctorate.

EDUCATION

Coursework completed toward a doctorate in Administration of Higher Education at the University of Arkansas
(Instructor of graduate class on grantwriting)

Ed.S. Higher Education in Administration, Pittsburg State University, 1985

M.S. Community College Education / English, Pittsburg State University, 1983

B.A. English, Washburn University, 1975

PROVEN TRACK RECORD

TRIO Success Rate

RMA's success rate on TRIO grants is 100% for existing projects and over 80% for new projects, nearly twice the national rate.

We assisted 25 institutions with Talent Search Applications in 2001. Grantees will be notified in May or June 2002.

- In 2000, we worked on 29 successful Student Support Services Grants
- In 1999, we worked on 19 successful Upward Bound grants and 1 successful McNair grant. (100% success rate)
- In 1998, we worked on 7 successful Talent Search grants. (60% success rate)
- In 1997, we worked on 15 successful Student Support Services grants. (88% success rate)

In addition, we consistently are awarded five-year rather than four-year grants, meaning the proposals score in the top 15% of all applications nationwide.

TRIO CLIENT REFERENCES

RMA assisted many of these colleges with one or more TRIO (Upward Bound, Student Support Services, Talent Search and McNair) projects.

Dr. Donald Schoening (President)
Arizona Western College
Phone: (520) 344-7501

Dr. David Caffey (Dean)
Clovis Community College (NM)
Phone: (505) 769-4010

Dr. Robert Dunker (President)
Western Iowa Technical Comm College
Phone: (712) 274-6400

Ann Tomlinson
Antelope Valley College (CA)
Phone: (616) 722-6537

Dr. Barbara Viniar (President)
Berkshire Community College (MA)
Phone: (431) 499-4660 x281

Dr. Luba Chliwniak (Dean)
Cochise College (AZ)
Phone: (520) 515-5400

Dr. Marie Giacomelli (Vice President)
Robert Morris College (IL)
Phone: (217) 726-1666

Daniel Seymour (Dean)
Los Angeles City College
Phone: (323) 953-4096

Connie Bonfy (Dir. of Institutional Research)
Cowley County Community College (KS)
Phone: (620) 441-5308

Dr. Eileen Piwetz (Resource Development)
Midland College (TX)
Phone: (915) 685-4526

John Garofoli (President)
Eastern Oklahoma State College
Phone: (918) 465-2361 x245

Dr. Jim Hill (President)
Neosho County Community College
Phone: (316) 431-2820

C.c. Nelson (Director of Development)
New Mexico Junior College
Phone: (505) 392-5723

Paul Thein (Vice President)
Feather River Community College (CA)
Phone: (530) 283-0202 x273

Mark Kern (President)
Rend Lake College (IL)
Phone: (618) 437-5321

*Dr. Vic Morgan (President)
Sul Ross State University (TX)
Phone: (915) 837-8032

Dr. Robert Westrick (President)
Lake-Sumter College (FL)
Phone: (352) 365-3523

Barbara Roeder (Dir. of College
Advancement)
Hawkeye Community College (IA)
Phone: (319) 296-2329 x1279

*Susan Craig (Dir. of Student Support
Services)
Missouri Southern State College
Phone: (417) 625-9828

Dr. James Henderson (President)
San Juan College (NM)
Phone: (505) 599-0209

Dr. James Utterback (President)
Seminole State University (OK)
Phone: (405) 382-9200

Kelvin Sharp (Vice President)
South Plains College (TX)
Phone: (806) 894-9611 x2207

Kathy O'Dell
Southwestern Illinois College
Phone: (618) 235-2700 x5493

Robert Sprague (Vice President)
West Los Angeles College
Phone: (310) 287-4405

*Denotes UB grantees

Dr. John Pruitt (Vice President)
Northeast Texas Community College
Phone: (903) 572-1911

Dr. Larry Devane (President)
Redlands College (OK)
Phone: (405) 262-2552

*Dr. Narasinga Rao
University of Central Oklahoma
Phone: (405) 974-2524

Dr. Herb Swender (President)
Frank Phillips College (TX)
Phone: (806) 274-5311 x715

*Dr. Penny Jarecke (Dir. of Student Support
Services)
Los Angeles Southwest College
Phone: (323) 241-5229

Dr. Sharon Katterman (Vice President)
Moraine Valley Community College (IL)
Phone: (708) 974-5768

Bethene Fahnstock (Dir. of Institutional
Research)
Northeastern Oklahoma State University
Phone: (918) 540-6948

Dr. Terry Ludwig (President)
Shawnee Community College (IL)
Phone: (618) 634-3200

Archie Blair (Dir. of Resource Development)
Southeastern Illinois College
Phone: (618) 252-6376 x2120

Dr. Don Huff (President)
Weatherford College (TX)
Phone: (817) 594-5471 x271

Clayton Tatro (Dean)
Garden City Community College (KS)
Phone: (316) 276-9539

Unique Fee Structure for Professional Services Allows Ramona Munsell & Associates to Take the Risk with the College

Successful applications are never a sure thing - even with expert help and an excellent proposal. The selection process is extremely competitive and very subjective. RM&A is willing to work with colleges on a contingency basis. There is no up-front fee until the college obtains a grant. We know of no other full-time consultants who are willing to work primarily on a contingency basis. Our successful track record allows us to work under this unique arrangement.

Our contingency fee is payable only when a grant is received. For this fee, a college receives:

- Extensive assistance in planning a project and preparing a competitive proposal (including access to recent, top-rated proposal);
- Extensive writing and proposal development services;
- Invitation to RMA Upward Bound proposal development workshop - no registration fee;
- Assistance in understanding the applicable federal regulations (including providing valuable guides to these regulations which are updated regularly);
- Extensive grant management assistance once the project begins (to facilitate internal and external reporting and ensure adherence to federal regulations);
- Assistance in preparation of required applications and performance reports for continued funding;
- Assistance with supplemental funding requests;
- Assistance in preparing for any official site visits or audits of the project which occur during or after the project.
- Unlimited telephone assistance on day-to-day grant management issues;
- Assistance with prior approval revisions and documentation for compliance purposes.

To our knowledge, there are no other firms that:

- **Specialize full time in TRIO and Title III / V;**
- **Work under a contingency agreement,**
- **Have a comparable success rate, and**
- **Provide comprehensive services after a grant is obtained.**

TIMELINE AND PLAN OF APPROACH

Assuming a deadline of October 1, 2002 for FY 2002 Upward Bound Proposals, the following timeline is proposed:

<i>April - June</i>	<ul style="list-style-type: none"> • Provide training workshop to New Mexico Junior College contact person. • Develop overall strategy for funding. • Identify data requirements material needed to support activities. • Provide samples, and verbal and written guidelines/instruction.
<i>July</i>	<ul style="list-style-type: none"> • Work with contact person to draft Need section and Commitment section. • Write final draft of Need and Commitment sections. Submit electronically to College. • College adapts existing plan of operation and sends to RMA.
<i>August</i>	<ul style="list-style-type: none"> • RMA rewrites as needed and submits electronically to College. • Work with contact person(s) to complete other sections: <ul style="list-style-type: none"> • Letters of Commitment • Evaluation / Objectives • Plan of Operation
<i>Early to mid-September</i>	<ul style="list-style-type: none"> • Edit / fine-tune each section.

We recommend an approach similar to the one used in the past. Some material (Need section and Commitment section) will originate with New Mexico Junior College (using our guidance / material) and come to us for rewrite. Material will be transmitted electronically via fax and e-mail attachments. Unless the College prefers otherwise, we will assign an associate to work closely with the College through this process. Timelines can be adjusted if work needs to be accomplished by end of summer.

PROPOSED FEE FOR UPWARD BOUND GRANT PROPOSAL ASSISTANCE

Ramona Munsell & Associates proposes to charge New Mexico Junior College a contingency fee of 3.5% (of the annual grant amount), to be payable quarterly commencing when the grant begins (September 1, 2003).

For this total fee (no additional charges), Ramona Munsell & Associates will provide the college during the four or five year grant period the total range of services described in this response to New Mexico Junior College's Request for Proposals #66 and other services requested by the college which are needed to achieve project objectives, manage the project and solve any grant management problems which occur.

Two copies of a Memo of Understanding are included with this response. If New Mexico Junior College accepts our proposal, please sign and return one copy.

Signed by:



Ramona Munsell, President

March 8, 2002



MEMORANDUM OF UNDERSTANDING

RAMONA MUNSELL & ASSOCIATES (hereinafter referred to as "RMA") appreciates the opportunity to be of assistance to **NEW MEXICO JUNIOR COLLEGE** (hereinafter referred to as "college") in its efforts to develop a successful Title IV application under the Upward Bound Program (Federal TRIO Programs). RMA will provide consultation and writing services to the college in developing an Upward Bound application.

Assuming the grant is obtained, the services of RMA will also include, when requested, assistance in establishing appropriate program and fiscal controls, technical assistance for project implementation, and assistance with annual performance reports and revision requests during the term of the grant.

It is understood that during the development phase of the Title IV Upward Bound proposal, RMA agrees to waive the standard upfront fee.

It is also agreed that should the proposal be successful as a result of the joint efforts of RMA and the college, the college will pay RMA a fee equal to three and one-half percent (3.5%) of the funds awarded by each annual grant award document during the term of the grant. Payment of RMA's contingency fee **must** be made from non-grant funds in equal, quarter-annual installments, commencing with the date the grant begins.

Memo of Understanding
RMA / New Mexico Junior College

In the event that the joint efforts of the college and RMA are unsuccessful during the 2002/2003 funding cycle, the college and RMA are released from further obligations (pertaining to this agreement) of one to the other.

It is agreed that RMA will only serve in a consultant or advisory capacity and that the college retains its decision-making powers in both the preparation of the proposal and grant management.

If you agree with RMA's understanding of this agreement as set forth in this Memorandum, please sign and return two copies of the memorandum. A signed, fully executed document will be returned to you for your records.

RAMONA MUNSELL & ASSOCIATES

**NEW MEXICO JUNIOR
COLLEGE**

By: _____
President

By: _____
President

Date: _____

Date: _____

NEW MEXICO JUNIOR COLLEGE

Invitation To Bid #919

**Installation of Air Conditioning Units for
NMJC Del Norte Center**

BOARD DOCUMENTS

Date:	March 11, 2002
Prepared by:	Frank Collins Coordinator of Purchasing

NEW MEXICO JUNIOR COLLEGE

BOARD DOCUMENTS

General Information

1. On February 15, 2002 a legal notice was posted on the NMJC Bulletin Board and sent to the following newspapers requesting sealed bids for the installation of air conditioning units at the NMJC Del Norte Center:
 - 1) The Hobbs Daily News Sun
 - 2) Las Cruces Sun News
 - 3) Albuquerque Journal
2. Proposal packets were delivered to thirteen (13) potential bidders. Packets were also forwarded to two contractor reporting firms (these firms post bids and request for proposals for various types of contractors to review).
3. Three vendors submitted proposals within the time frame specified by the proposal package. Two vendors appeared at the bid opening.
4. The Business Office and Maintenance Department have evaluated the bids received and their recommendations are shown on Page 2.

NEW MEXICO JUNIOR COLLEGE

Evaluation and Recommendations

Board Documents

Three vendors responded to Invitation to Bid #919. They were A.G. Custom Sheet Metal Air Conditioning & Heating; Marker Services, Inc.; and Certified Air Conditioning & Appliance, all of Hobbs, NM.

The results of the Invitation are shown on Page 3 (Tabulation Summary).

The Administration recommends acceptance of the bid submitted by Certified Air Conditioning & Appliance, Hobbs, NM for an amount of \$24,347.47. The cost breakdown is shown on Page 3A.

Source of Funding: 2001/2002 Fiscal Year - Building Renewal & Replacement ("BRR")

Account #: 9-2729-02-119 – HVAC for Del Norte Center Amount: \$24,347.37

NEW MEXICO JUNIOR COLLEGE
Invitation to Bid #919
BID QUOTE FORM

The undersigned as an authorized representative of the company whose information is contained herein and on page five, proposes to furnish the equipment as stated in the specifications above within the time specified and conditions set forth, at the price indicated below (the vendor must include full specifications for all equipment bid including warranty information).

1. **Air Conditioning Units and Accessories (12.5 Ton/7.5 Ton/ (2) 5 Ton)**
Equipment (Attach Specifications & Warranty Information) \$ 12,447.99

Attached YES/NO

2. **Labor - Installation of A/C Units and Materials** \$ 2,579.95

2A. **Duct System Materials** \$ 3,850.88

2B. **Labor - Duct System Installation** \$ 2,545.79

3. **Labor - Demolition and Removal of Existing Unit (from lower roof)** \$ 150.00

4. **Electrical Materials** \$ 997.80

5. **Labor - All Electrical work** \$ 1,675.06

6. **Cost of Permits** \$ 100.00 (aprox)

TOTAL COST OF LABOR & MATERIALS FOR ENTIRE PROJECT \$ 24,347.47

Have All Specifications Been Met according to Invitation? YES/NO

If "NO", please indicate exceptions in detail on a separate sheet of your letterhead.

Please Note Any Exceptions On An Attached Sheet

SIGNATURE PAGE:

Certified Air Conditioning
Name of Company

Richard Polon
Signature of Authorized Representative

2-27-02
Date

505-397-5965
Phone Number

NEW MEXICO JUNIOR COLLEGE

Invitation to Bid #919

SPECIFICATIONS

Installation of New Air Conditioning Units At NMJC Del Norte Center

Vendor proposes to provide to NMJC services as specified below:

Scope of Work

Vendor shall provide all equipment, materials, and labor to install 30 tons of new air conditioning units on the Del Norte Center. The equipment shall consist of One (1) 12.5 Ton, One (1) 7.5 ton and Two (2) 5 ton air conditioning units. One (1) 5-ton unit shall be installed above the glass courts and One (1) 5 ton air conditioning unit shall be installed on the low roof to replace the existing unit with gas heat. Complete duct system (exposed on the roof of the structure) shall be performed giving the high roof 25 tons of air conditioning. Electrical work must be included in the project work scope. An on site inspection of the area requiring work is required before the bid package will be accepted by New Mexico Junior College. It is the contractor's responsibility to determine that the equipment will fit in the space available and is of proper arrangement. All deliveries shall be scheduled in advance with the New Mexico Junior College Physical Plant and must be received entirely by **April 22, 2002**.

All equipment must be new and have the original manufacturer's warranty.

Specifications

Equipment/Units:

Specifications to be equal to or better than Comfort Maker 10 Seer Units.

Project Area Requirements:

Contractor is responsible for any clean up required from their scope of work. All parts from demolition and removal of existing air conditioning unit on low roof must be removed from the project area by the contractor.

NEW MEXICO JUNIOR COLLEGE

Invitation To Bid #919

SPECIFICATIONS (Continued)

Project Area Requirements Continued:

The contractor will note that student and community individuals will be visiting the Center during all phases of the work. The contractor shall take all necessary precautions to protect all members visiting the Center.

The contractor may not use interior facilities of the Center, but must provide its own temporary toilet facilities.

Access areas must be identified and posted as danger areas. Any equipment, supplies, or materials may be stored inside the access area. The construction site must be cleaned daily and kept free of unnecessary trash and debris. All items must be stored neatly within the project area.

Barriers must be erected around the construction area and will be limited to contractor's personnel and representatives of the NMJC Del Norte Center and the College.

New Mexico Junior College will not be responsible for security of contractor's equipment, materials, supplies, or vehicles.

Successful contractor shall provide all MSDS data sheets for materials being used for this project. Contractor shall comply with all applicable provisions of OSHA, State, and Local Regulations.

Work Schedule:

All work must begin by **April 24, 2002** and be completed no later than **May 10, 2002**.



Submittal Data

For Approval

Project: NEW MEXICO JR COLLEGE

Date: February 28, 2002



Submitted by: MORRISON SUPPLY CO
904 E. 2nd
ODESSA, TX. 79761



Project: NEW MEXICO JR COLLEGE

Table of Contents

System ID	Qty	Model No	Description	Page
PAD150H000	1	PAD150H000	Package Electric	3
PAF060H000	1	PAF060H000	Package Electric	6
PAF090H00A	1	PAF090H00A	Package Electric	9
PGF060H100	1	PGF060H100	Package Gas	12



Project: NEW MEXICO JR COLLEGE Schedule No.: PAD150H000
 Model Number: PAD150H000 Quantity: 1

PAD150H000	
Cooling Performance	
Gross Total Capacity	149,400 btu
Gross Sensible Capacity	115,038 btu
Efficiency (at ARI)	8.50 EER
	8.10 IPLV
Total Air Supply	5000 cfm
Outdoor DB Temp	95.0 °F
Entering DB Temp	80.0 °F
Entering WB Temp	67.0 °F
Leaving DB Temp	58.7 °F
Leaving WB Temp	57.7 °F
Supply Air Performance	
Total Supply Air	5000 cfm
External Static Pressure	.30 in. w.g.
Blower Type	Belt
Blower speed	865 RPM
Power Input	2320 Watts
Motor Rating	3 hp
<i>Airflow calculated with dry coil and filter</i>	
Electrical Data	
Power Supply	208/230 volts
	3 Phase
	60 Hertz
System Ampacity	68.1 Amps
Maximum Fuse Size	80 Amps

- Options Selected**
- AXB050CMA - 14 inch Roof Curb



Project: NEW MEXICO JR COLLEGE Schedule No.: PAD150H000
 Model Number: PAD150H000 Quantity: 1

CONVERTIBLE SINGLE PACKAGE AIR CONDITIONING UNIT

- Electric cooling, self contained for year round comfort. Systems can be installed on rooftop or ground level.

CABINET

- Triple-coated steel, consisting of a Polyester top coat, a urethane primer coat preceded by an oxide pretreatment.
- Fork-lift access on three sides. Holes provided for lifting lugs makes rooftop installation easier.
- Access panels for easy service. Side by side supply and return. Heavy 16 gauge base with rails.

INDOOR BLOWER

- Standard belt drive blower
- "No Difference" Design -- Unit will operate at the same rated External Static Pressure in the down shot or horizontal duct position.

COOLING SYSTEM

- Two Stage Cooling
- Enhanced aluminum fins mechanically bonded to copper tubes for improved heat transfer.
- Freeze stat protects refrigeration circuits at low saturated suction temperatures
- High and Low pressure switch to provide excellent compressor protection.
- Externally-Mounted Gauge Ports Allows for more accurate reading of operating conditions while servicing.
- Equipped with high efficiency scroll compressors.

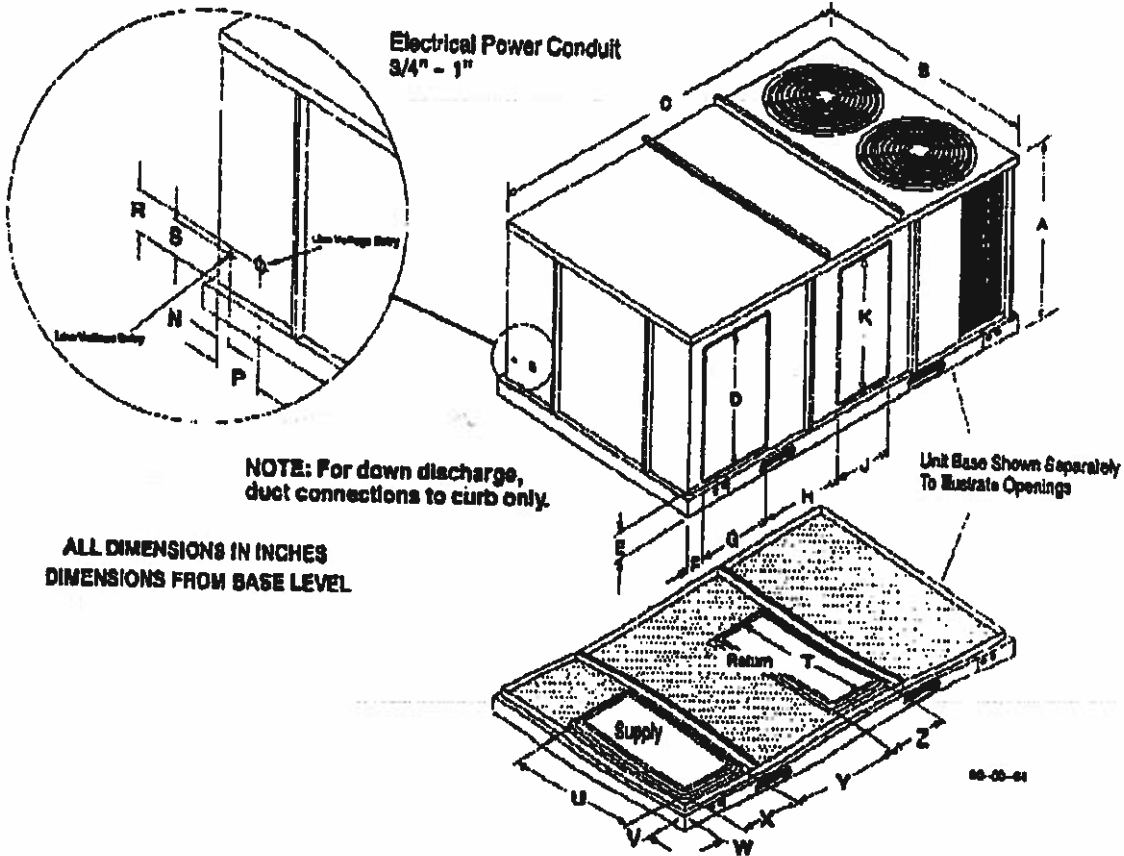

ALL DIMENSIONS IN INCHES
 DIMENSIONS FROM BASE LEVEL

NOTE: For down discharge, duct connections to curb only.

Unit Base Shown Separately To Illustrate Openings

06-05-01

Unit Dimensions (in.)									
A	B	C	D	E	F	G	H	J	K
48-13/16	68-1/8	89-15/16	41-3/16	5-1/8	4-1/2	21-9/16	15-1/4	21-9/16	41-3/16
N	P	R	S	T	U	V	W	X	Z
2	8-3/4	5-7/8	2	45-1/16	45-1/16	3-1/2	3-1/2	24-1/2	24-1/2



Project: NEW MEXICO JR COLLEGE Schedule No.: PAD150H000
 Model Number: PAD150H000 Quantity: 1

RIGGING DETAILS

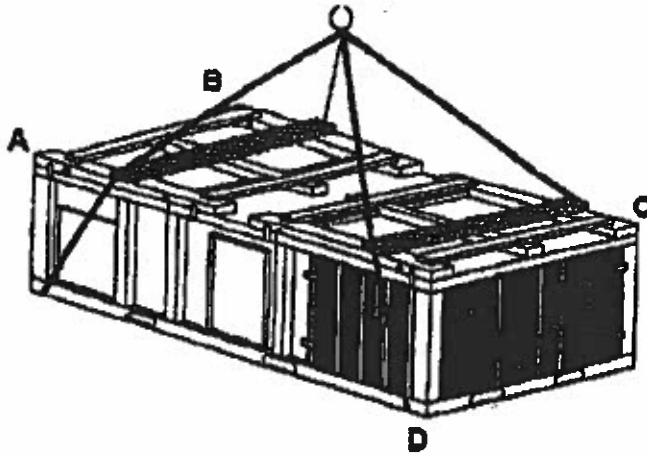

Corner Weights (lbs.)				
A	B	C	D	Operating Weight Total
253	362	359	251	1267

INSTALLATION CLEARANCES

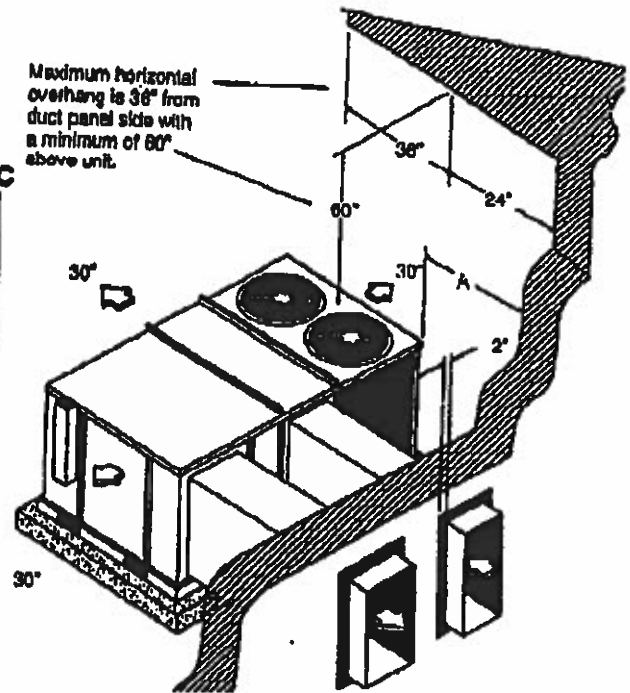

A = 24" with no economizer; 48" with economizer;

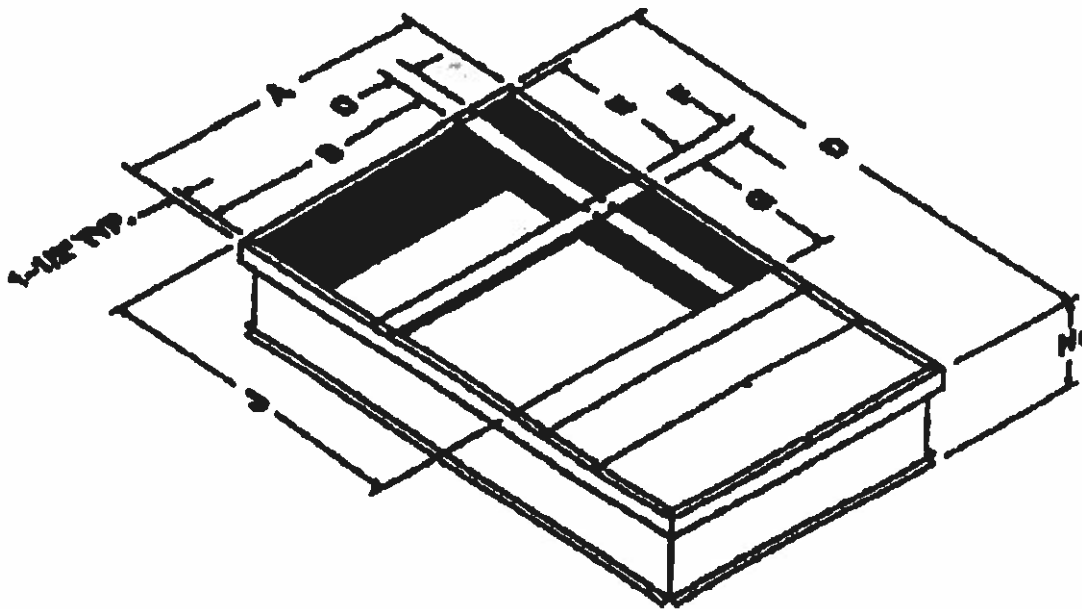

Roof Curb Dimensions (In.)									
A	B	C	D	E	F	G	H	J	
61-1/2	44	3-1/2	93-3/8	28-1/2	3-1/4	28-1/2		61-3/4	



Project: NEW MEXICO JR COLLEGE Schedule No.: PAF060H000
 Model Number: PAF060H000 Quantity: 1

PAF060H000	
Cooling Performance	
Gross Total Capacity	61,874 btu
Gross Sensible Capacity	46,633 btu
Efficiency (at ARI)	8.70 EER
	10.00 SEER
Total Air Supply	2022 cfm
Outdoor DB Temp	95.0 °F
Entering DB Temp	80.0 °F
Entering WB Temp	67.0 °F
Leaving DB Temp	58.6 °F
Leaving WB Temp	57.4 °F
Supply Air Performance	
Total Supply Air	2022 cfm
External Static Pressure	.30 in. w.g.
Blower Speed	MD HI
Motor Rating	1 hp
<i>Airflow calculated with dry coil and filter</i>	
Electrical Data	
Power Supply	208/230 volts
	3 Phase
	60 Hertz
System Ampacity	30.6 Amps
Maximum Fuse Size	45 Amps

Options Selected
 • AXB020CMA - 14 Inch Roof Curb (AXB020)



Project: NEW MEXICO JR COLLEGE Schedule No.: PAF060H000
 Model Number: PAF060H000 Quantity: 1

CONVERTIBLE SINGLE PACKAGE AIR CONDITIONING UNIT

- Electric cooling, self contained for year round comfort. Systems can be installed on rooftop or ground level.

CABINET

- Triple-coated steel, consisting of a Polyester top coat, a urethane primer coat preceded by an oxide pretreatment.
- One Piece weather resistant top. Side by side supply and return. Heavy gauge base with rails.
- Standard direct drive blower
- Protective coil guard - standard

COOLING SYSTEM

- Equipped with high efficiency scroll compressor.
- Enhanced aluminum fins mechanically bonded to

copper tubes for improved heat transfer.

- Externally-Mounted Gauge Ports Allows for more accurate reading of operating conditions while servicing.

ELECTRICAL CONTROLS

- Factory wired to accept Econormizer
- Standard 65 VA transformer has built-in secondary circuit breaker standard

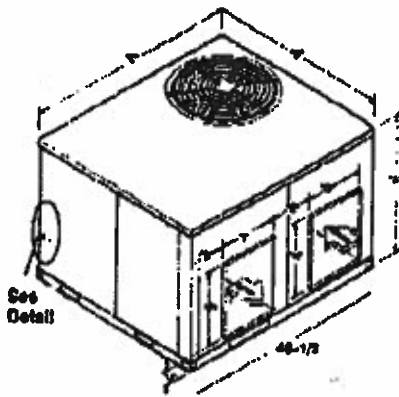

All-Dimensions in inches

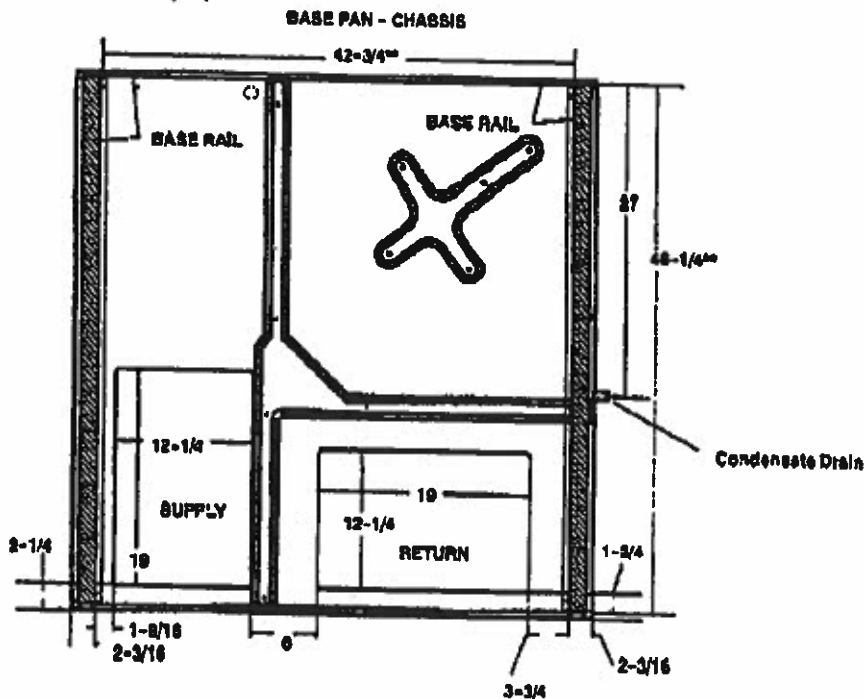
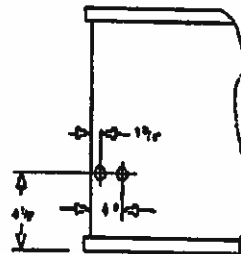

Unit Dimensions (in.)									
A	B	C	D	E	F	G	H	I	J
37-1/2	47-1/2	47-1/2	4	8-1/2	19	19	12	12	4-1/2



Project: NEW MEXICO JR COLLEGE Schedule No.: PAF060H000
 Model Number: PAF060H000 Quantity: 1

RIGGING DETAILS

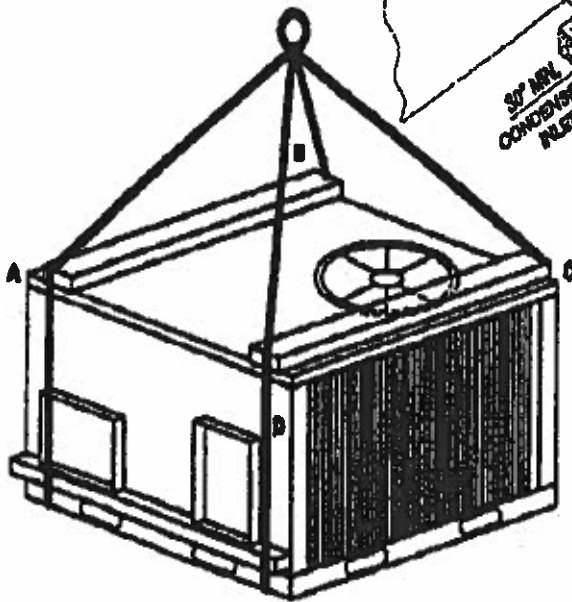

INSTALLATION CLEARANCES

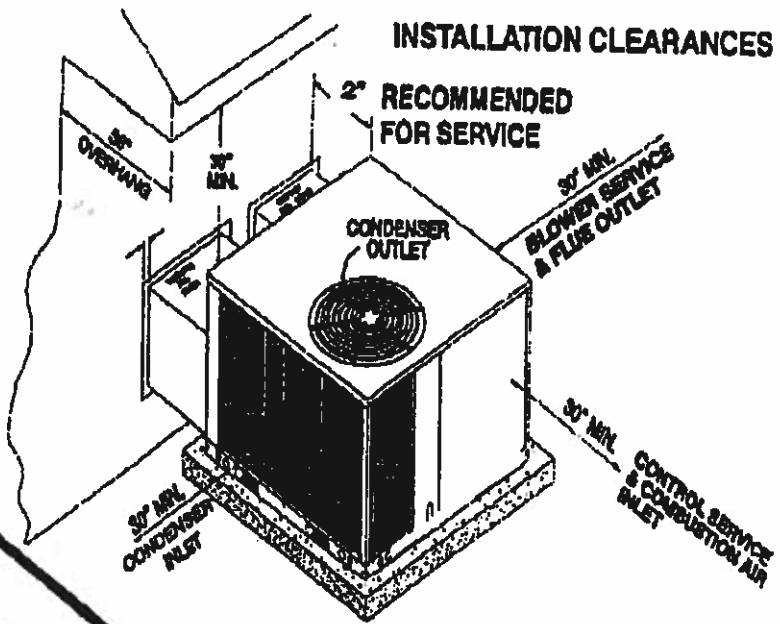

Corner Weights (lbs.)				
A	B	C	D	Operating Weight Total
100	125	175	100	500

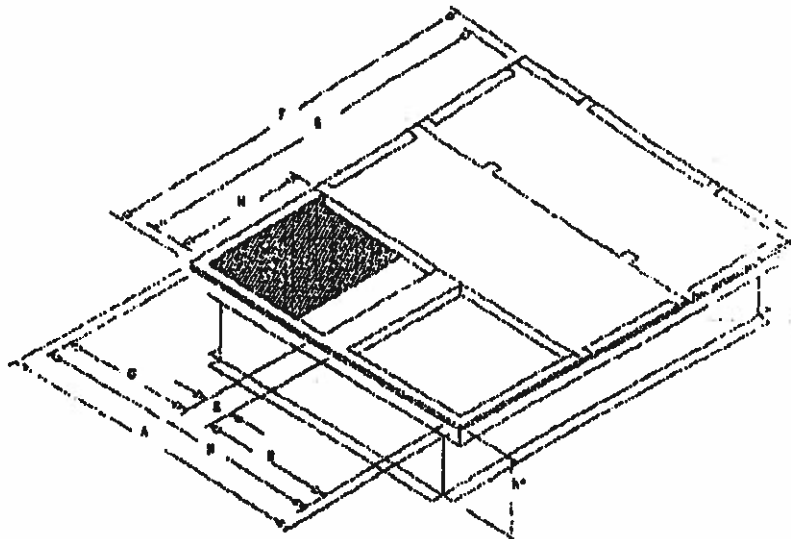

Roof Curb Dimensions (in.)							
A	B	C	D	E	F	G	H
42-3/4	39-3/4	18	18	3-3/4	42-3/4	38-3/4	18



Project: NEW MEXICO JR COLLEGE Schedule No.: PAF090H00A
 Model Number: PAF090H00A Quantity: 1

PAF090H00A	
Cooling Performance	
Gross Total Capacity	95,700 btu
Gross Sensible Capacity	70,818 btu
Efficiency (at ARI)	9.00 EER
Total Air Supply	3000 cfm
Outdoor DB Temp	95.0 °F
Entering DB Temp	80.0 °F
Entering WB Temp	67.0 °F
Leaving DB Temp	58.1 °F
Leaving WB Temp	57.0 °F
Supply Air Performance	
Total Supply Air	3000 cfm
External Static Pressure	.30 in. w.g.
Blower Type	Belt
Blower speed	1180 RPM
Power Input	1727 Watts
Motor Rating	2 hp
<i>Airflow calculated with dry coil and filter</i>	
Electrical Data	
Power Supply	208/230 volts
	3 Phase
	60 Hertz
System Ampacity	45.0 Amps
Maximum Fuse Size	70 Amps

Options Selected
 • AXB030CMA - 14 Inch Roof Curb



Project: NEW MEXICO JR COLLEGE Schedule No.: PAF090H00A
 Model Number: PAF090H00A Quantity: 1

CONVERTIBLE SINGLE PACKAGE AIR CONDITIONING UNIT

- Electric cooling, self contained for year round comfort. Systems can be installed on rooftop or ground level.

CABINET

- Triple-coated steel, consisting of a Polyester top coat, a urethane primer coat preceded by an oxide pretreatment.
- Access panels for easy service. Side by side supply and return. Heavy gauge base with rails.

INDOOR BLOWER

- Standard belt drive blower
- "No Difference" Design -- Unit will operate at the same rated External Static Pressure in the down shot or horizontal duct position.

COOLING SYSTEM

- Equipped with high efficiency scroll compressor.
- Enhanced aluminum fins mechanically bonded to

- copper tubes for improved heat transfer.
- Freeze stat protects refrigeration circuits at low saturated suction temperatures
- High and Low pressure switch to provide excellent compressor protection.
- Externally-Mounted Gauge Ports Allows for more accurate reading of operating conditions while servicing.

ELECTRICAL CONTROLS

- Factory wired to accept Economizer
- Standard 65 VA transformer has built-in secondary circuit breaker standard

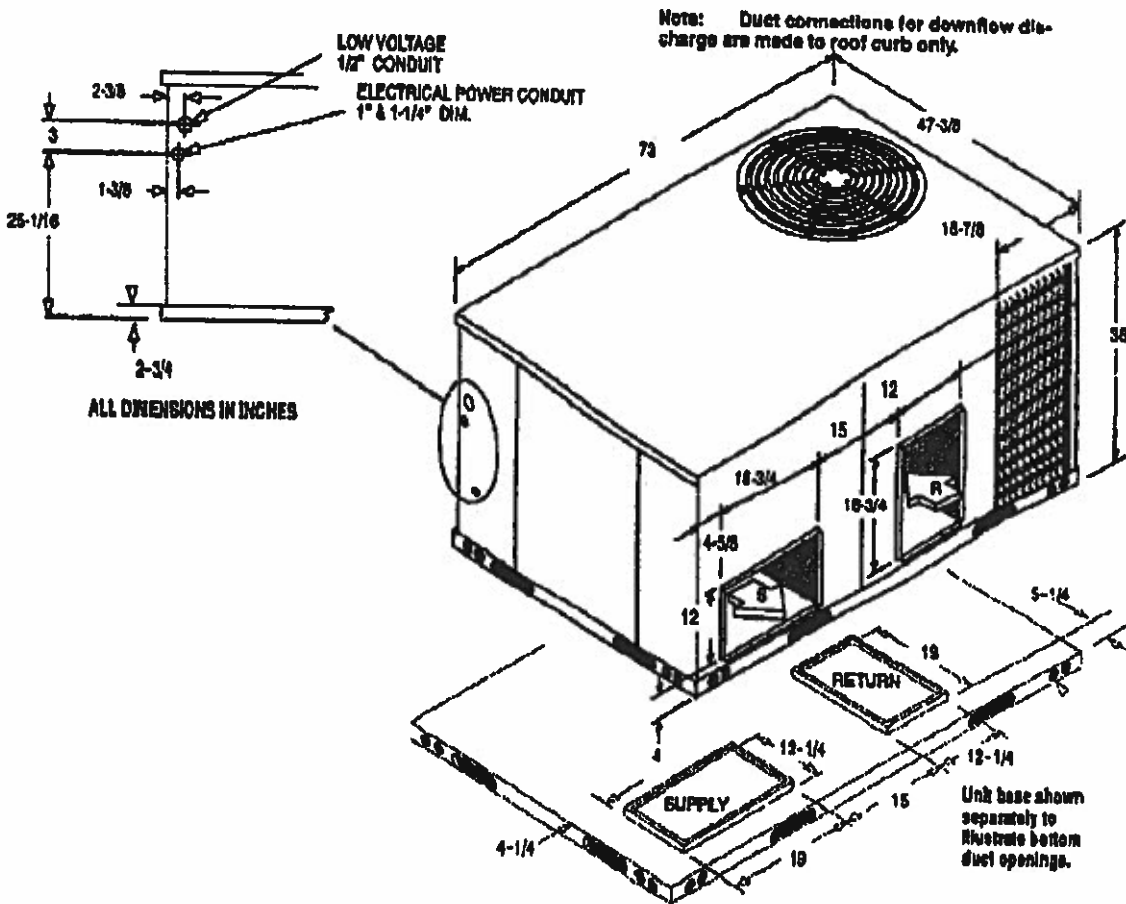



Project: NEW MEXICO JR COLLEGE Schedule No.: PAF090H00A
 Model Number: PAF090H00A Quantity: 1

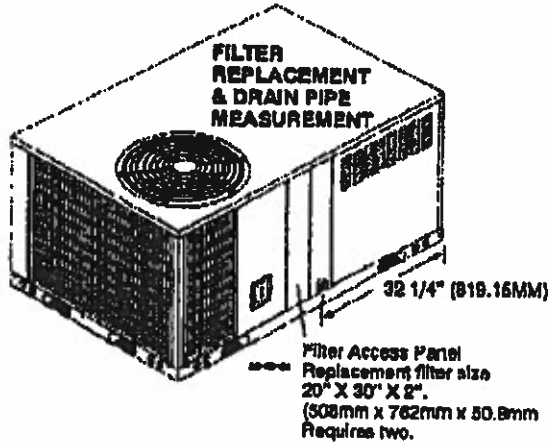

INSTALLATION CLEARANCES

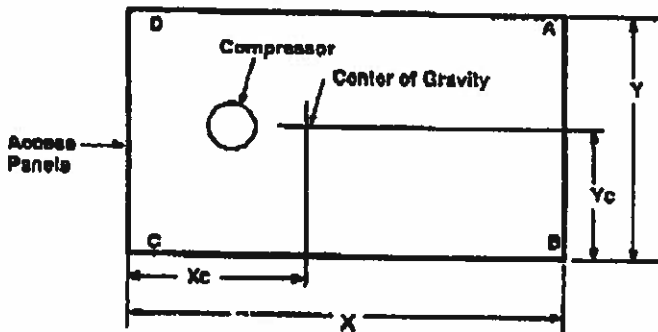
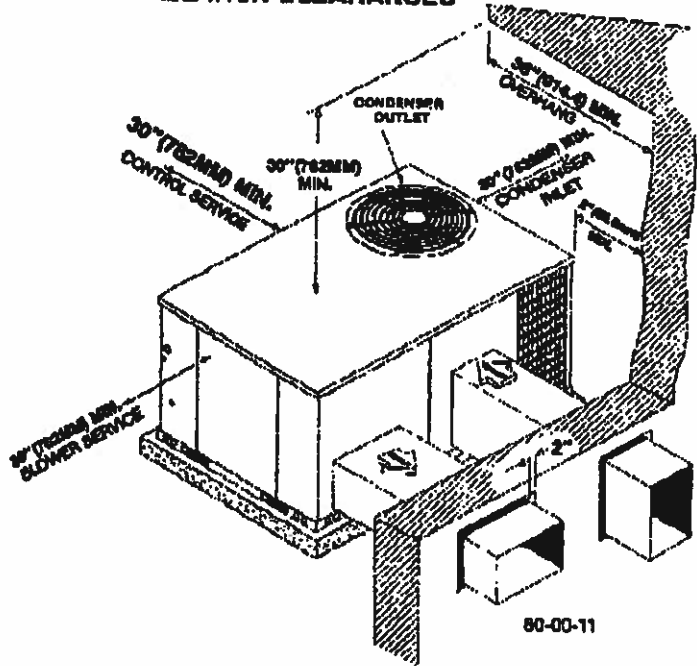

Corner Weights (lbs.)				
A	B	C	D	Operating Weight Total
134	188	207	148	677

Center of Gravity (in.)			
X	Y	Xc	Yc
73	47-3/8	34-3/4	19-3/4

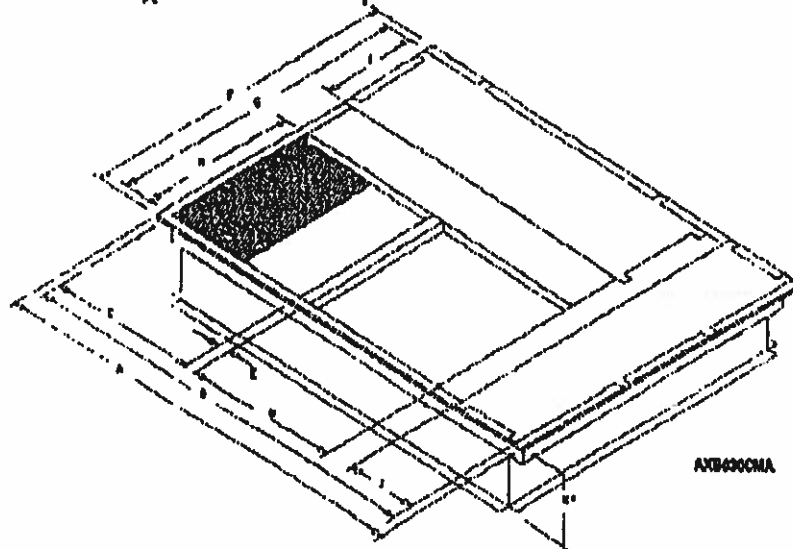

Roof Curb Dimensions (in.)									
A	B	C	D	E	F	G	H	I	J
67-3/4	64-3/4	23	23	2-1/2	42-3/4	39-3/4	23	12	12



Project: NEW MEXICO JR COLLEGE Schedule No.: PGF060H100
 Model Number: PGF060H100
 Quantity: 1

Options Selected

- AXB020CMA - 14 inch Roof Curb (AXB020)

PGF060H100	
Cooling Performance	
Gross Total Capacity	62,650 btu
Gross Sensible Capacity	48,241 btu
Efficiency (at ARI)	8.80 EER
	10.00 SEER
Total Air Supply	2014 cfm
Outdoor DB Temp	95.0 °F
Entering DB Temp	80.0 °F
Entering WB Temp	67.0 °F
Leaving DB Temp	57.8 °F
Leaving WB Temp	57.3 °F
Heating Performance	
Heating Capacity Input	100,000 btu
Heating Capacity Output	80,000 btu
AFUE	80.0%
California Efficiency	76.0%
Fuel Pipe Connection	1/2 in.
Supply Air Performance	
Total Supply Air	2014 cfm
External Static Pressure	.30 in. w.g.
Blower Speed	HI
Motor Rating	1 hp
<i>Airflow calculated with dry coil and filter</i>	
Electrical Data	
Power Supply	208/230 volts
	3 Phase
	60 Hertz
Total System Ampacity	30.9 Amps
Maximum Fuse Size	45 Amps



Project: NEW MEXICO JR COLLEGE Schedule No.: PGF060H100
 Model Number: PGF060H100
 Quantity: 1

CONVERTIBLE SINGLE PACKAGE GAS/ELECTRIC UNIT

- Combination gas heating and electric cooling, self contained for year-round comfort. Systems can be installed on rooftop or ground level.

CABINET

- Triple-coated steel, consisting of a Polyester top coat, a urethane primer coat preceded by an oxide pretreatment.
- One Piece weather resistant top. Side by side supply and return. Heavy gauge base with rails.
- Standard direct drive blower

COOLING SYSTEM

- Enhanced aluminum fins mechanically bonded to copper tubes for improved heat transfer.
- Externally-Mounted Gauge Ports Allows for more accurate reading of operating conditions while servicing.

ELECTRICAL AND GAS CONTROLS

- Electronic pilot Ignition device (HSP).
- Adjustable electronic fan control with optional low speed continuous fan feature responds quickly to circulate heated air and provide maximum comfort
- Factory wired to accept Economizer
- Standard 65 VA transformer has built-in secondary circuit breaker standard

HEATING SYSTEM

- Induced Draft Combustion system for smoother combustion and optimal efficiency
- Aluminized serpentine clamshell heat exchanger provides corrosion resistance for longer life and efficient heat transfer.
- In-Shot Burners

3 TO 5 TON

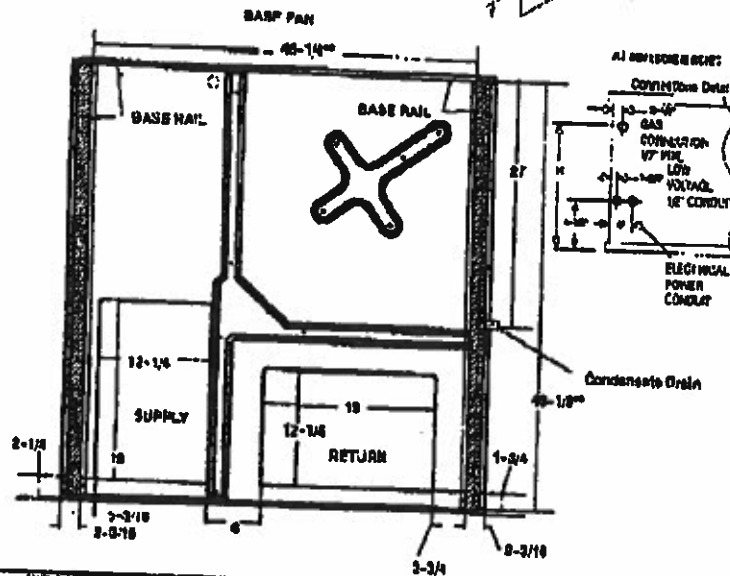
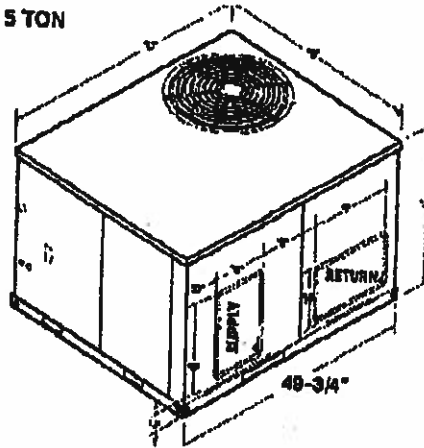

UNIT SIZE	A	B	C	D	E	F	G	H	I	J	K	L	M
3 TO 5 TON	37 1/2	27 1/2	31 1/2	7 1/2	4 1/2	11	12	12	13	1 1/2	6 1/2	48 1/4	8 3/4

Measured from outside to outside of base rails.



Project: NEW MEXICO JR COLLEGE Schedule No.: PGF060H100
 Model Number: PGF060H100 Quantity: 1

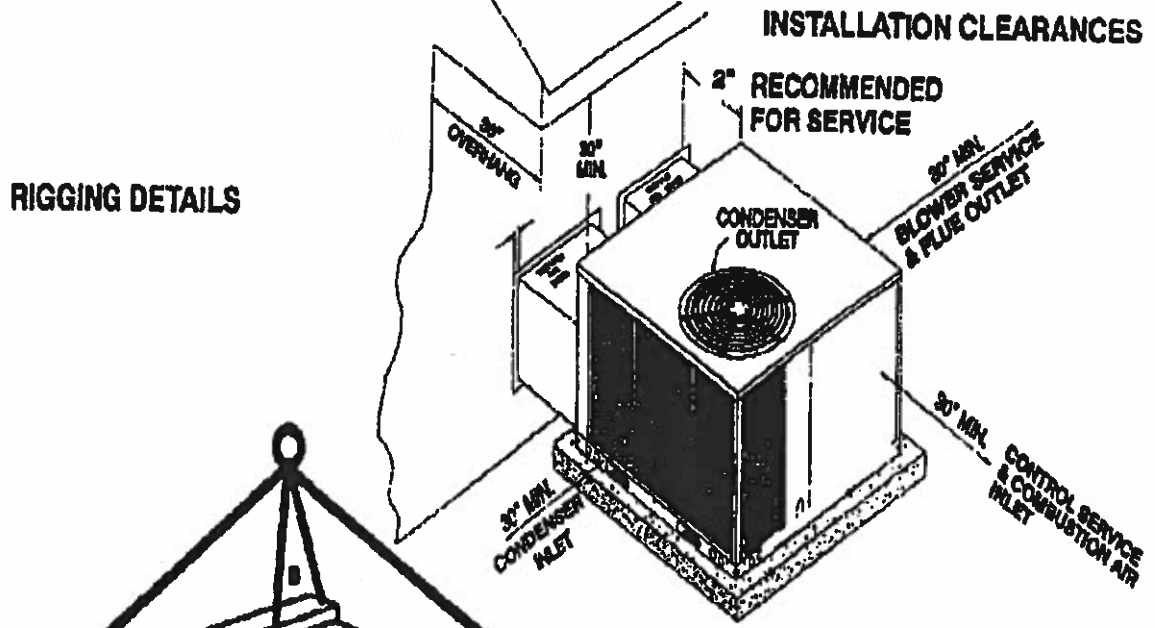

RIGGING DETAILS

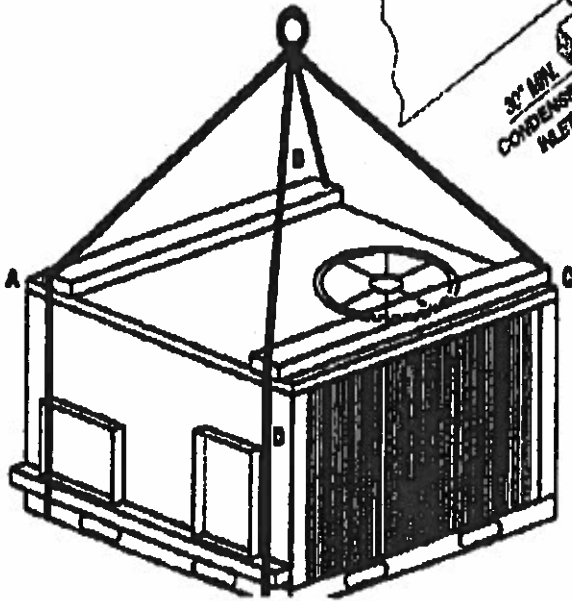

Corner Weights (lbs.)				
A	B	C	D	Operating Weight Total
100	125	175	100	500

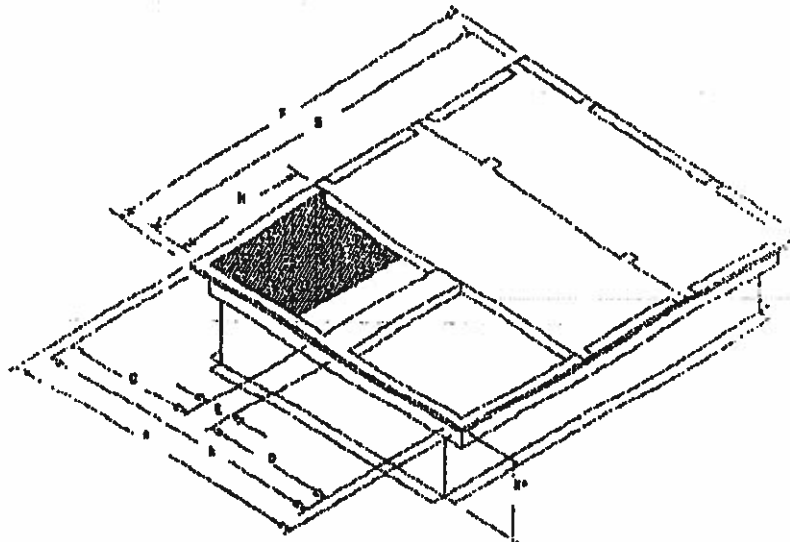

Roof Curb Dimensions (in.)							
A	B	C	D	E	F	G	H
42-3/4	39-3/4	18	18	3-3/4	42-3/4	39-3/4	18

ADDITIONAL TERMS FOR RESIDENTIAL APPLICATIONS ONLY

The Additional Terms for the components listed below are in addition to and subject to the General Terms on the reverse side of this page.

FURNACE HEAT EXCHANGERS*

1) CENTRAL GAS & OIL FURNACES

Gas Model Series: GUK, GUK, VNK, TNK, TCK, NTGM, NCGM, NCPM, NTVM, NTPM: Limited Lifetime Warranty - This additional Limited Warranty is to the original purchaser only for as long as the purchaser lives in the home where the furnace is initially installed. It provides a replacement primary or secondary heat exchanger. HOWEVER, this limited warranty is not transferable to any subsequent owner. If the furnace was not installed in the home owned by the original purchaser, if the original purchaser sells the home to a subsequent owner, or if proof of original purchase cannot be provided, then the limited warranty is only for 20 years from the date of original installation.

Gas Model Series: GDL, GNL, TNE, TDE, NTC7, NDK7, NTP6, NDP6, TDE: A replacement for 25 years from the original date of installation.

Gas Model Series: GNM, NTG9, NTC6, GNE, GDE, NDN6, NTG3, NTG5, FBI, NBI, NTN3, NTN6, NNE, GNP: A replacement for 20 years from original date of installation.

Oil Model Series: OEN, OEN, ODN, OLL, OLM, OML, OHL, NUOD, NI, OD, NI, OD, LLO5, LHO5, LMO5, LLO7, LHO7: This additional Limited Warranty is to the original purchaser only for as long as the purchaser lives in the home where the furnace is initially installed. It provides for a replacement primary or secondary heat exchanger. HOWEVER, this limited warranty is not transferable to any subsequent owner. If the furnace was not installed in the home of the original purchaser, if the original purchaser sells the home to a subsequent owner, or if proof of original purchase cannot be provided, then the limited warranty is only for 20 years from the date of original installation.

Oil Fired Floor Furnace: NFO: A replacement for 10 years from installation with the following limitation: during the sixth through tenth year, any cycle toward your purchase of a component or two and the purchase of any new unit will be at no amount equal to the distributor's purchase price reduced by 20 percent for each year after the fifth year.

2) GAS/ELECTRIC PACKAGED UNITS

Model series: PGAA, PGAA, PGMD, PGME, PGI, GPFM, PGC, GPCM: A replacement for 10 years from original date of installation.

COMPRESSORS*

1) Premium Model Units: FBA2, AH, AJ, YG, YL, ACS2, CA90, CA96, KNS5, CH95, CH96, PGME, PYMC, PHAD, PGAD, PA95, PAPS: To the original purchaser a replacement for 10 years from original date of installation, only if the unit is installed with factory matched coils. This limited 10-year warranty is not transferable to any subsequent owner. HOWEVER, if the unit was not installed in the home owned by the original purchaser, if the purchaser sells the home to a subsequent owner, or if proof of original purchase cannot be provided, then the limited warranty is only for 5 years from the original date of installation.

2) All Other Models: Air Conditioners, Heat Pumps, & Combination Gas/Electric Units: AG, YL, CH55, FBA, AC3, FBV, HPS, C455, PGI, PGC, GPFM, GPCM, PAF, APFM, PIG, HPPM, PGAA, PGMD, PAAA, PAMB, PA55, P155, PAPA, PVPA: A replacement for 5 years from date of original installation, only if: (a) air conditioner/condensing units with SEER rating in the range of 10 are matched with evaporator coils of the same nominal tonnage regardless of manufacturer and in accordance to factory recommendations, or (b) heat pump condensing units are used with factory matched coils, unless written approval to do otherwise is obtained from manufacturer.

ADDITIONAL TERMS FOR COMMERCIAL APPLICATIONS ONLY

For purposes of this warranty a commercial application is one in which the product has over 5 tons nominal cooling capacity, or is designed for operation with 3 phase electrical power, or is installed in a commercial establishment such as a beauty or hair salon, hospital, school, restaurant, church, hotel etc.

The additional terms of the components listed below are in addition to and subject to the General Terms on the reverse side of this page.

1) FURNACE HEAT EXCHANGERS (ALL MODEL S):* A replacement for 10 years from date of original installation.

2) COMPRESSORS (ALL MODEL S):* A replacement for 5 years from date of original installation.

3) OPTIONAL ACCESSORIES AND FUNCTIONAL COMPONENT PARTS (ALL MODEL S):* A replacement for 1 year from date of original installation.

*To receive advantage of your limited warranty, you must provide proof of yearly service by a qualified service technician.

**To receive advantage of your warranty, you must retain the original records that can establish the installation date and proof of purchase of the unit.

NEW MEXICO JUNIOR COLLEGE

Invitation To Bid #920

Automotive Equipment & Supplies

BOARD DOCUMENTS

Date:	March 14, 2002
Prepared by:	Frank Collins Coordinator of Purchasing

NEW MEXICO JUNIOR COLLEGE

BOARD DOCUMENTS

General Information

1. On February 13, 2002 a legal notice was posted on the NMJC Bulletin Board and sent to the following newspapers requesting sealed bids for automotive equipment and supplies:
 - 1) The Hobbs Daily News Sun
 - 2) Las Cruces Sun News
 - 3) Albuquerque Journal
2. Bid packets were delivered to seven potential bidders.
3. Four vendors submitted proposals within the time frame specified by the proposal package. No vendors appeared at the bid opening.
4. The Business Office and Automotive Department have evaluated the bids received and their recommendations are shown on Page 2.

NEW MEXICO JUNIOR COLLEGE

Evaluation and Recommendations

Board Documents

Four vendors responded to Invitation to Bid #920. They were Transportation Supplies, Inc., St. Paul MN, NAPA Auto Parts, Hobbs, NM, Crest Step On, Houston, TX, and Southwest Tools, Hobbs, NM.

The results of the Invitation are shown on Page 3 (Tabulation Summary).

The Administration recommends acceptance of the multiple award bid as follows:

Crest Step On: \$995.00

Transportation Supplies, Inc.: \$1,406.19

Southwest Tools: \$1,421.06

NAPA Auto Parts: \$5,697.39

Total Awarded for this Bid: \$9,479.64

Source of Funding: 2001/2002 Fiscal Year - Vocational Support Services – (Carl Perkins Grant)

Account #: Major Equipment – 3 –2741 – 43 – 141
Minor Equipment – 3 – 2641 – 43 - 141
Supplies & Expense – 3 –2435 – 43 - 141

Total: \$9,479.64

ITB #920 Quote Tabulation Summary				Crest Step On, Inc.			Transportation Supplies, Inc.				
New Mexico Junior College				Part #(P) or Model(M) #	Brand Name	Qty Bid by Vendor	Bid Price Per Item	Total Bid Price Quote	Qty Bid by Vendor	Bid Price Per Item	Total Bid Price Quote
Qty	Item & Description										
1	Fascar Brake Fluid Test Strips - 100 strips per tube	1-100			No bid				1	\$34.96	\$34.96
1	Universal Cap Adapter	UCA-100-2	MaxPro Universal		No bid				1	\$130.75	\$130.75
1	Maxi-Jet Pro Brake Bleeder	205	Maxpro		No bid				1	\$217.31	\$217.31
1	Vision 100 Headlamp Aimer	196-00005	Hoppy		No bid				1	\$1,289.00	\$1,289.00
2	Sure Step 1 - color Yellow	164-R5500	Sure Step	2	\$477.50	\$955.00				No bid	
1	Brake Washer - All Vehicle	164-R1208	Clayton		No bid				1	\$578.99	\$578.99
1	Brake Washer Supply Kit	500-252	Clayton		No bid				1	\$115.31	\$115.31
1	Software for Exhaust Analyzer	3341-02	OTC		No bid				1	\$33.91	\$33.91
1	Cable for Exhaust Analyzer	3341-06	OTC		No bid				1	\$145.85	\$145.85
1	5 - Gas Exhaust Analyzer	3718	OTC		No bid				1	\$5,769.00	\$5,769.00
1	Magnetic Crack Detector	9292	Kline		No bid				1	\$592.66	\$592.66
1	Crack Inspection Kit	KL 9275	Kline		No bid				1	\$431.60	\$431.60
	Total Awarded					\$955.00					\$1,246.19
	Grand Total of all Awards										\$9,479.64